

GHP & EHP Hybrid Air Conditioner

Test Run Manual

July 2018

Applicable Models

U-20GES3E5

U-10MES2E8

CONTENTS

- Tools and measuring equipment 1



SAFETY PRECAUTIONS

Stopping only the indoor unit is extremely dangerous because the engine may suddenly start if the customer operates the remote controller on the indoor unit. When working on internal parts of the outdoor unit, make sure to cut the power to the outdoor unit at the circuit breaker before starting work. (However, if a centralized control device such as an intelligent controller is used, a communications error may occur.) Otherwise, perform a “Stop” operation on the outdoor unit.

I . Check before operation

- 1. Checking installation work I - 1

II . Preparations and Test Run Procedures

- IMPORTANT II - 1
- SAFETY PRECAUTIONS II - 2
 - 1. Precautions II - 3
 - 2. Test Run Procedure II - 3
 - 3. Setting the Fuel Gas Type (If Band P (LPG) is Used) II - 6
 - 4. Checking the Date and Time in the GHP outdoor unit II - 6
 - 5. Checking the Initial Settings in the GHP outdoor unit II - 7
 - 6. Checking and Setting the Fuel Gas Type in the GHP outdoor unit II - 8
 - 7. Setting the Number of Connected Indoor/Outdoor Units in the GHP outdoor unit. II - 8
 - 8. Setting the System Address and Outdoor Unit Address in the GHP outdoor unit II - 9
 - 9. Settings for the unit number setting, number of outdoor units, number of indoor units,
and system addresses on the U-10MES2E8 II -10
 - 10. Setting Terminator Status II -11
 - 11. Items to Check before the Test Run II -12
 - 12. Checking Refrigerant Tubing and Control Cable Connections between Indoor/Outdoor Units II -13
 - 13. Setting the Indoor Unit Addresses (Automatic Addresses) II -13
 - 14. Test Run Settings II -14
 - 15. Diagnostic Self-Check List (GHP) II -18
 - 16. Diagnostic Self-Check List (U-10MES2E8) II -20
 - 17. Checking the Indoor Unit Addresses II -22
 - 18. Changing the Indoor Unit Addresses (If Necessary) II -23
 - 19. Precautions II -23

III . Checking the function and performance

- 1. Checking the function III - 1
- 2. Checking performance III -14

IV . Reference Document

- 1. U-20GES3E5 IV - 1
- 2. U-10MES2E8 IV - 2

V . GHP Test Run Checklist V - 1

●Tools and measuring equipment

	Item	Specification	Q'ty	Notes
Tools and equipment	Driver	(+) S, M, L (-) M	1 each	
	Monkey wrench	150mm/200mm/250mm	1 each	
	Spanner		1 set	
	Leak detection liquid		Appropriate quantity	
	Step ladder		1	
	Socket wrench		1 set	
	Cloth		Appropriate quantity	For wiping the leak detection liquid
	Ordinary tools		1 set	
Measurement equipment	Insulation resistance meter	DC 500 V	1	
	Gas leak detector		1	
	PC for monitoring		1 unit	Including connecting cable

I . Checking before operation

1. Checking installation work

(1) Installation work check

- ① If there is a problem with the installation work, make a request through the sales representative that the problem be remedied and measures be taken.
- ② Write the necessary information in the “GHP Test Run Checklist (2WAY Multi/W Multi). (Refer to the appendix.)

(2) Outdoor unit check

① Applicable Gas Type

Group		P	H	L	E
Gas composition Standard gas Calorific value (MJ/m ³ N)		C ₃ H ₈ 100% G31 95.65	CH ₄ 100% G20 37.78	CH ₄ 86% N ₂ 14% G25 32.49	CH ₄ 100% G20 37.78
Model Name	45.0 kW Type	○	◎	○	○
	56.0 kW Type	○	◎	○	○
	71.0 kW Type	○	◎	○	○
	85.0 kW Type	○	◎	○	○

Applicability ◎ : Standard setting when shipped from the factory

○ : Necessary to change the gas type setting on site

② External appearance check

- Confirm visually that there is no external damage to the product caused during transport or subsequently.
- In particular, the heat exchanger fan is easily scratched, and some customers have pointed out scratches when outdoor units were handed over. Be careful.

③ Accessory check

Required accessories	Storage location	Remarks
Instruction manual	These items are all stored in a plastic bag which is attached to the inside of the face panel with the display window for the operation time.	Explain how to use the manual when you hand it over to the customer.
Warranty		Fill in the relevant items when you hand over the warranty to the customer.
Labels		<ul style="list-style-type: none"> ● Remote power switch label ● Refrigerant tube length and refrigerant charge amount ● Label for a seal ● Warning label

- ① After operation is finished, check that items such as the instruction manual and warranty have not been lost when handing over the outdoor unit to the customer.
- ② A list of all the accessories is included in “Procedures and Technical Points for System Installation,” but the accessories required after installation are those shown in the table above.

* In addition to the table above, the following are supplied with the outdoor unit at the time of shipment. Refer to them together with this test run manual.

- Procedures and Technical Points for System Installation
- Procedures and Technical Points for Electrical Wiring Work
- Procedures and Technical Points for Test Run

(3) Safety check

① Insulation resistance check

Perform the following procedure to check the insulation up until the unit power terminal block.

- ❶ Turn off the main power supply of the indoor and outdoor units.
- ❷ Turn off the power switch in the terminal box of the outdoor unit.
- ❸ Connect the insulation tester between each of the power terminals of the R phase, O phase, and S phase and the ground terminal on the power terminal block (TBI) in the terminal box, and take measurements. (Figure 1)
If a resistance check is required on the outdoor unit side, turn on the power switch in the terminal box, and take measurements.

* Measurement criterion: 1 MΩ or more

(2) Fuel tube connector leak check

- ❶ Open the liquid tube cock.
- ❷ Use a gas leak detector (Figure 2), soap solution, or the like to check that there is no leak from the fuel tube connector of the outdoor unit.

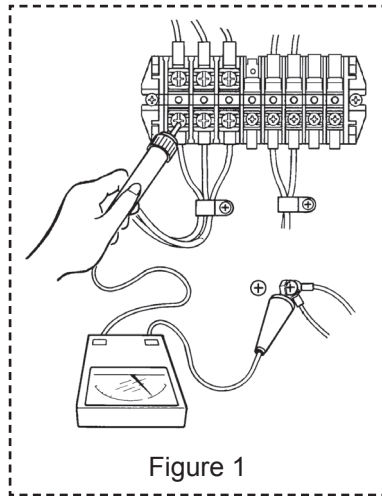

Figure 1

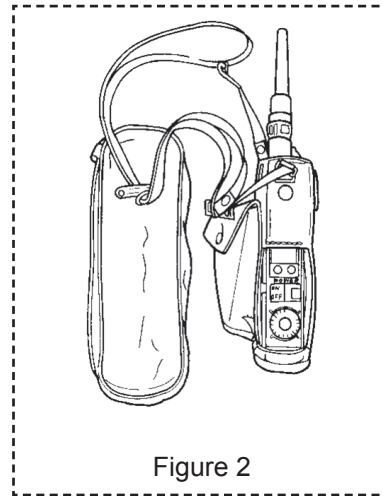

Figure 2

(4) Indoor/outdoor control wire connection confirmation

Check the indoor/outdoor control wire connection regardless of whether there is a warning or not. Before performing the check, turn off the power of all devices (including controllers) that are connected to the indoor/outdoor control wire.

1. Ground fault check	1-1	Measure the resistance between one end of the indoor/outdoor control wire and the point of ground screw, as well as the resistance between the other operating line end and the point of ground screw. Are both measured resistance values in MΩ unit (infinite)?	Yes	2-1
			No	1-2
	1-2	Because the indoor/outdoor control wiring has a ground fault, search for the location of the ground fault.		
2. Short circuit check	2-1	Measure the resistance between the indoor/outdoor control wires on the terminal board of the outdoor unit. The measured resistance value is around 75 to 100Ω? When setting multiple "ON (SHORT)" to switches with terminal resistor, the resistance value mentioned above is 1 over number of units. *1	Yes	3-1
			No	2-2
	2-2	If the wiring has a short circuit, search for the location of the short circuit on the indoor/outdoor control wire. If it is open, check the terminal resistor of outdoor board, and check the wiring from outdoor board to outdoor terminal board.		
3. Wire break or disconnection check	3-1	Measure the resistance between the indoor/outdoor control wires on the boards of all devices that are connected to the control wires. Any location with measured resistance values in MΩ units (infinite)?	Yes	3-2
			No	4-1
	3-2	Because the wiring has a break, search for the location of the break.		
4. Shield wire check	4-1	A shield wire is used as an indoor/outdoor control wire?	Yes	4-2
			No	5-1
	4-2	Only one end of the shield wire is grounded?	Yes	5-1
			No	4-3
	4-3	Ground only one end of the shield wire.		
5. Others	5-1	Check total wire length and the number of branch connections and connected units.		

* Terminal resistor is basically "ON (SHORT)" for one unit only, but depending on the installation status can be set to "ON (SHORT)" for up to 3 units.

- Device ground check
Is earth ground securely obtained?
- If an error is found in the wiring connections, the following check procedure allows you to quickly identify the location of the error. When performing the check procedure, it is convenient if you have a drawing showing the layout of devices and wiring routes to refer to.
 - In systems that are comprised of multiple wiring systems linked together, you can quickly identify the location of the error by removing the 'link' and determining whether each individual system is good or not good. A warning in a certain system does not necessarily mean that the cause of the error is in that system. Check the indoor/outdoor control wires of all systems, since the abnormality may be in the wiring of a system other than that where the warning is triggered.

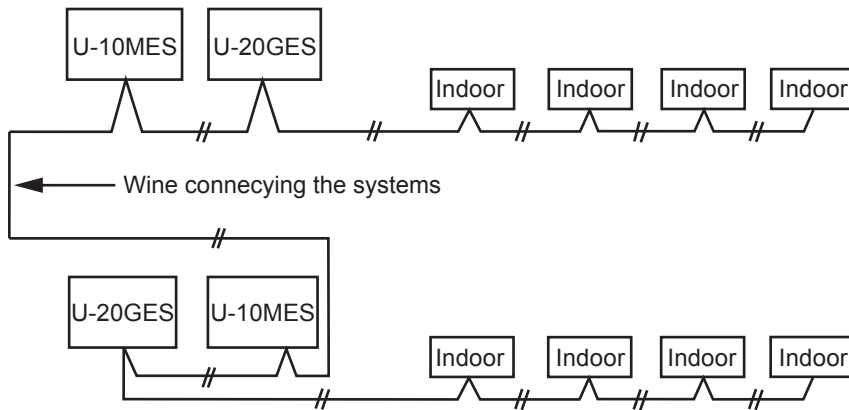

- When the wiring route is divided into segments by the terminal block of each unit, it is advisable to check the wiring connection on a segment by segment basis, starting with the segment between the outdoor unit and indoor unit 1, then the segment between the indoor units 1 and 2, and so on. This allows you to find the location of the connection failure between units.

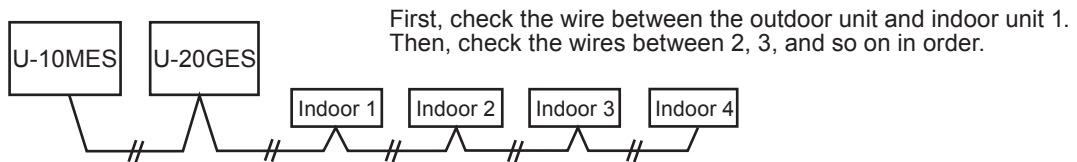

- If the device contains operation wire branched from indoor/outdoor control wire, there may be failure in the indoor/outdoor control wire before branches.

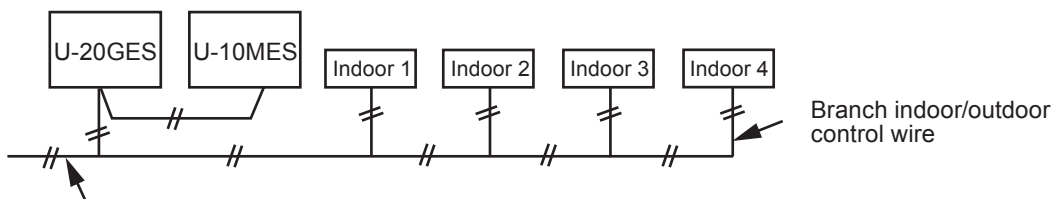

Ground faults or short circuits can also occur in the indoor/outdoor control wiring before branches.

- If communication error occurs, check the sensor's ground fault.
- Check sensors (thermistor) ground fault.
Before checking, turn off the device and remove target sensor from the board before performing measurement.

6. Ground fault check		Measure the resistance between one end of the indoor/outdoor control wire and the point of ground screw, as well as the resistance between the other operating line end and the point of the ground screw. Are both measured resistance values in MΩ unit (infinite)?	Yes	Good
	6-1		No	6-2
	6-2	Replace thermistor and wiring		

Ground fault check

Measure resistance between the ground screw and terminal board 1.
 Measure resistance between the ground screw and terminal board 2.
 Standard: ∞

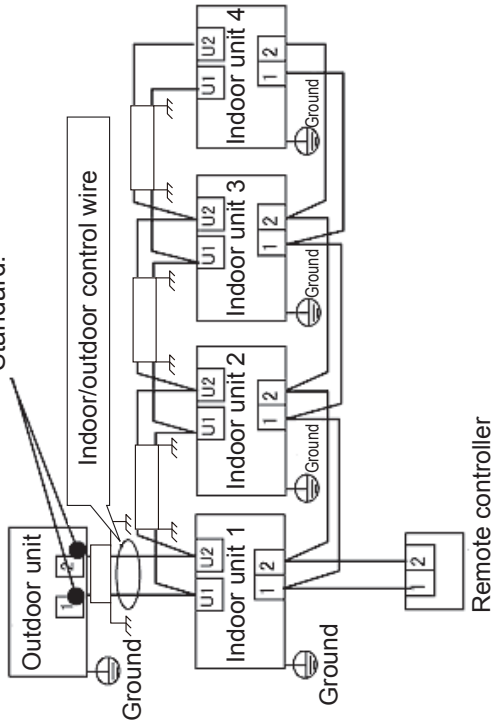

Short circuit check

Measure resistance between terminal board 1 and terminal board 2.
 Standard: Approx. 75 to 100 Ω (with one terminal resistor present)

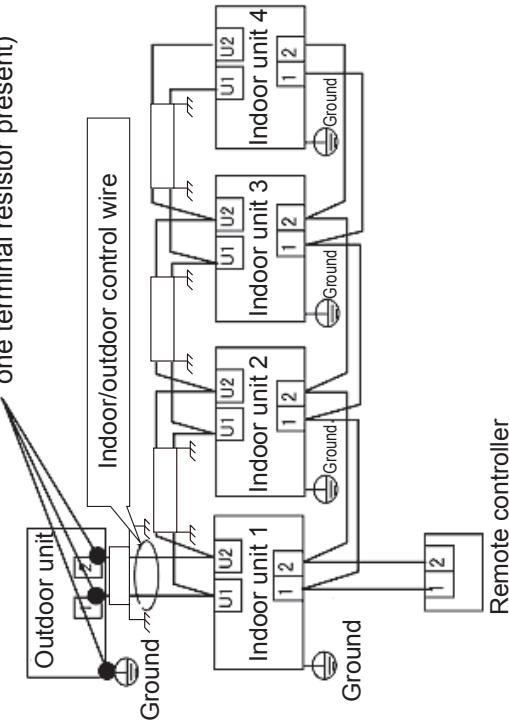

Wire break or disconnection check

Measure resistance on the terminal board of each unit.

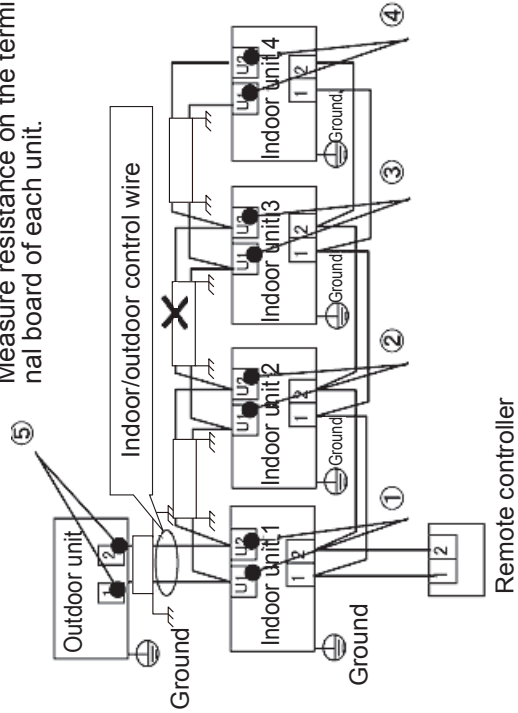

Example: A wire break or disconnection occurs at x (with one outdoor unit terminal resistor present).
 The resistance value for ①, ②, and ⑤ is approx. 75 to 100 Ω .
 The resistance value for ③ and ④ is ∞ .

* If the resistance for ⑤ is ∞ , check the terminal resistor for the outdoor main board, and check wiring between the outdoor main board and the outdoor unit terminal board.

Sensor ground fault check (* Sensor ground faults will also result in communication faults.)

· Sensor type (thermistor) ground fault check (turn off power for units)
 For each of the indoor/outdoor units connected by the operation cable, measure the resistance between the sensor wiring and ground screw for both of the sensor wires and ground screws.

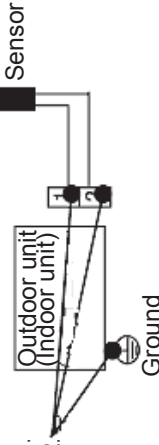

Measure resistance between the ground screw and terminal board 1.
 Measure resistance between the ground screw and terminal board 2.
 Standard: ∞
 If there is resistance, a sensor ground fault has occurred.

① Number units to connect

① Number of units to connect

- Maximum possible number of outdoor units..... 30
 - Maximum possible number of indoor units..... 64
 - Maximum possible number of centralized control devices..... 10
- (* Total number of each device within 1 link wire is up to 100.)

② Wires

- Thickness : 0.5 mm² to 2 mm²
- Total length : Total maximum length of up to 1 km
- Precautions
 - 1) To avoid incorrect operation, do not run the signal cable together with the power line cable.
 - 2) Keep the separation distance of 50 mm or more from the power line cable for Panasonic air conditioning equipment.
 - 3) Keep the separation distance at 300 mm or more from other power line cables.
 - 4) If the wires are to be run together within the distances described above, insert one of them in a conduit made of iron.
 - 5) When using a shielded wire, ground either one of the cables.
 - 6) Do not use the same wire for the signal wires and power supply wires. (Figure 3)
 - 7) Do not use a multi-core wire for a set of signal wires. (Figure 4)
- 8) Wiring
 - a) A bus system shall basically be used for multiple systems. (Figure 5)
 - There should be no more than 16 branch locations. (Figure 5)
 - Make sure wiring between branch locations and branch points is 2 m or more. (Figure 5)
 - If there will be 17 or more branches, split the system into two and then connect the wire. (Figure 6)
 - Not include in branch within 1 m. (Figure 7)
 - Use up to three wires for a branch. Four or more wires are prohibited. (Figure 8)
 - A branch after the branching of a wire is prohibited. (Figure 9)
 - Loop wiring is prohibited. (Figure 10)
 - b) A daisy chain system shall basically be used for a single system. (Figure 11)
- Terminal resistor
 - When linking multiple outdoor units, keep the terminal resistor of two units (SHORT), and set OPEN for the other units. If a communication error occurs, keep the terminal resistor of the three units (SHORT).

③ Remote controller wiring

- Wiring : Between remote controller and indoor unit : non polar 2-line format
: Between indoor units : non polar 2-line format
- Wire thickness : 0.5 mm² to 2 mm²
- Wire length : Total wiring length is max 500m.
(If wireless remote controller exist within group (RCS-BH80BN.WL, SH80BN.WL), wire is up to 400m.)
Total wiring between indoor units is up to 200m ($l_1+l_2+l_3+... l_n = \text{Max } 200\text{m}$)

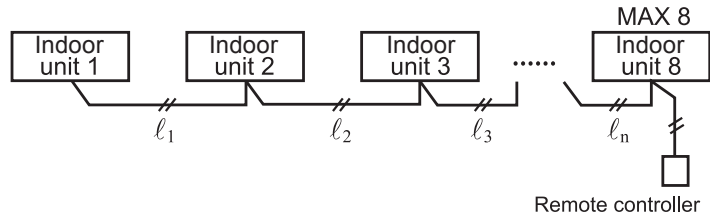

• Cautions

- i) To avoid incorrect operation, do not run the signal cable together with the power line cable.
 - ii) Keep the separation distance of 50 mm or more from the power line cable for Panasonic air conditioning equipment.
 - iii) Keep the separation distance at 300 mm or more from other power line cables.
 - iv) If the above cables are run within the separation distance mentioned above, place either one of the cable in a conduit.
 - v) If shielded wire is used, ground either one of the cables.
 - vi) For signal cable, do not wire it using the same cable as power cable. (Figure 3)
 - vii) Do not wire signal cables using multi-wick cable. (Figure 4)
 - viii) If there is high frequency devices nearby, place the unit at 3 m away from the device.
- * Place the remote controller in steel box, and the remote controller wire in a steel conduit or steel connect tube.

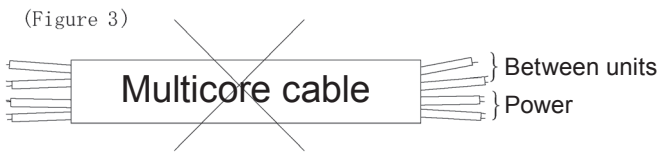

② Control wire

* Indoor/outdoor control wire connection example

❶ Bus system (can be branched to max 16 location). Outdoor link is basic. (Figure 5)

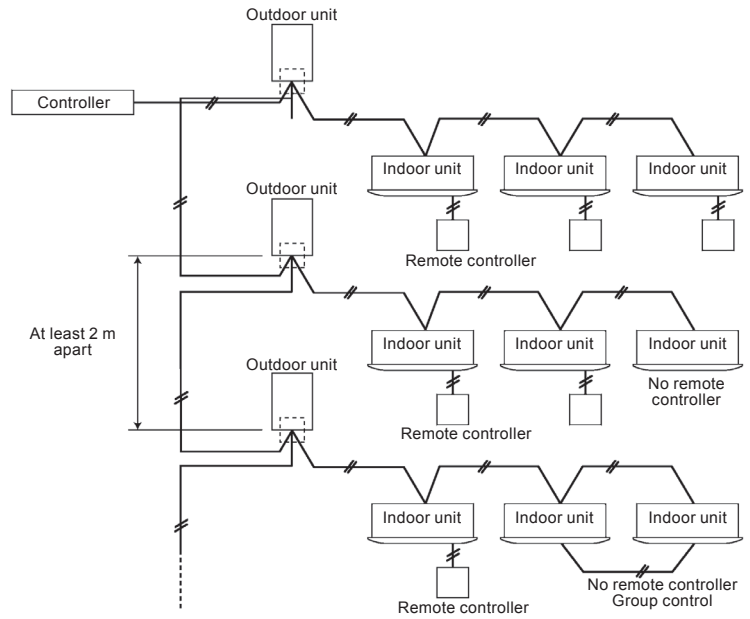

Figure 5

❷ In ❶, if there are more than 17 branches, reduce the number of branch locations. (Figure 6)

<Example>Putting 2 refrigerant systems to 1 wiring system

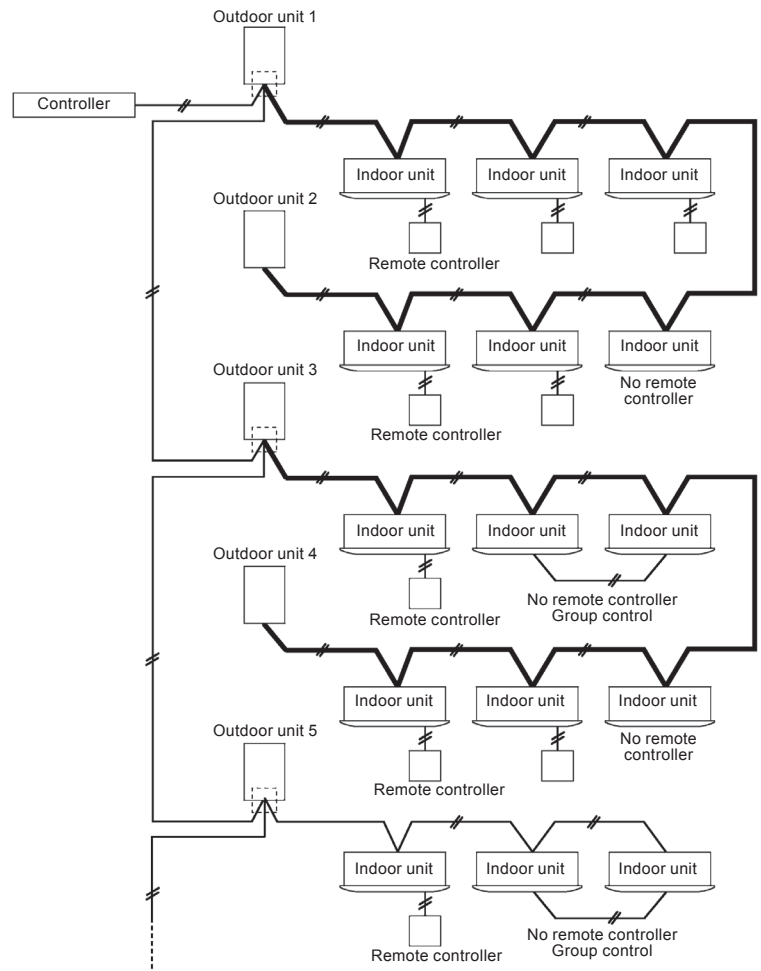

Figure 6

- ③ Wiring without branching (Figure 7)
Column: Part of indoor wiring branches.

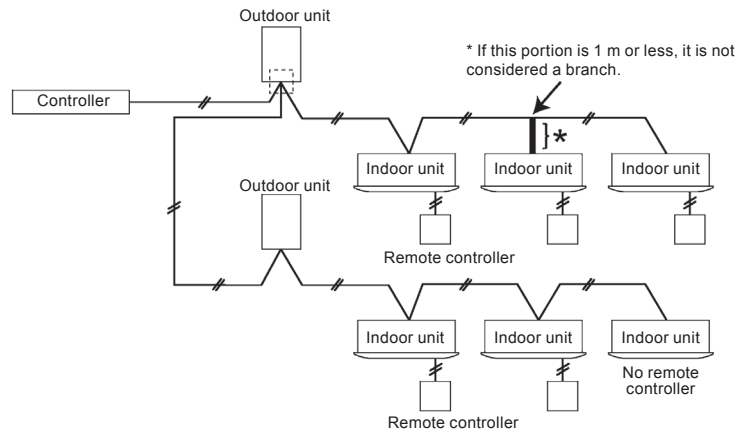

Figure 7

- ④ Star system is prohibited. (Figure 8)

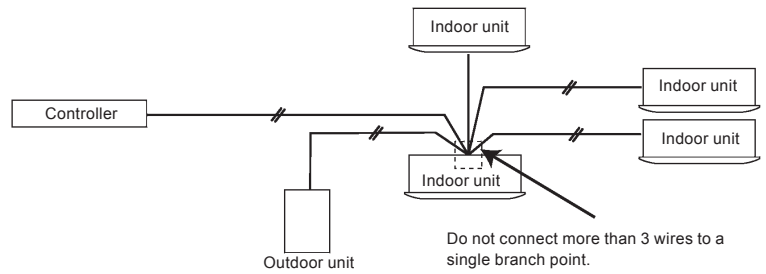

Figure 8

- ⑤ Branches after branching (branching of location that cannot be branched in a single stroke) are prohibited. (Figure 9)

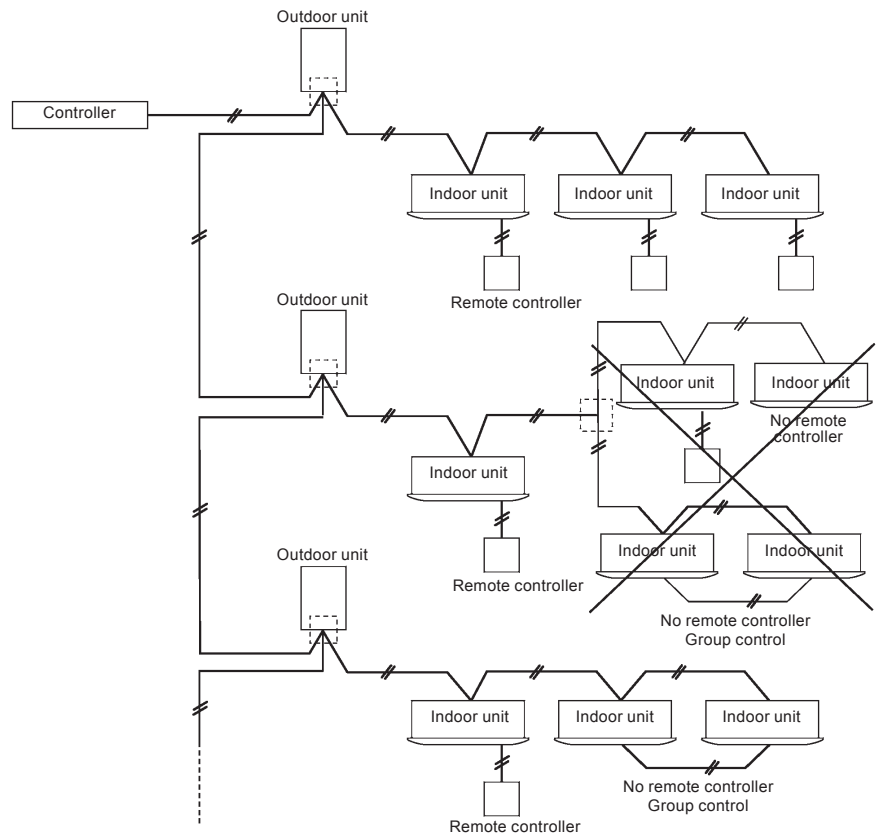

Figure 9

⑥ Loop wiring is prohibited. (Figure 10)

Example: As shown in the figure, do not have wiring where part of it is looped or the entire wiring is looped.

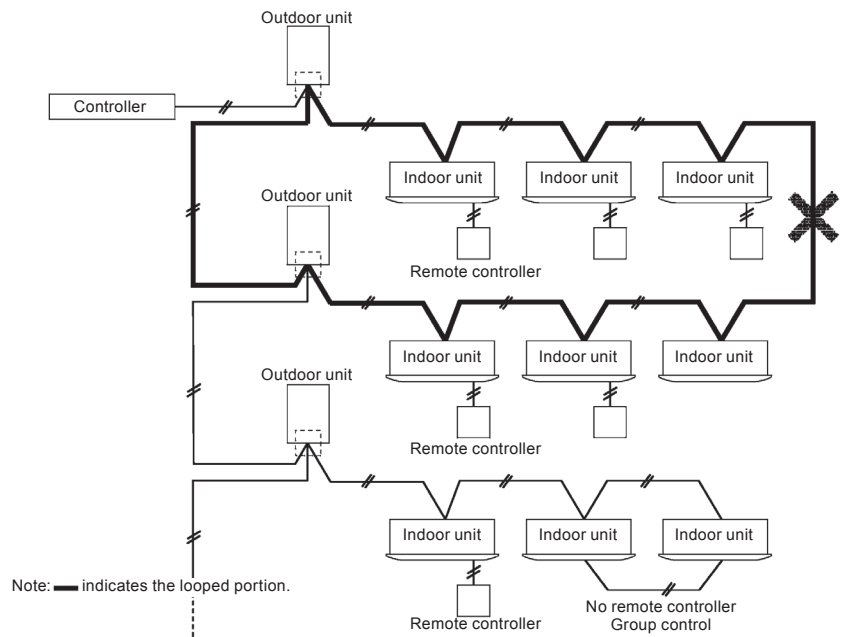

Figure 10

⑦ Daisy chain system (Figure 11)

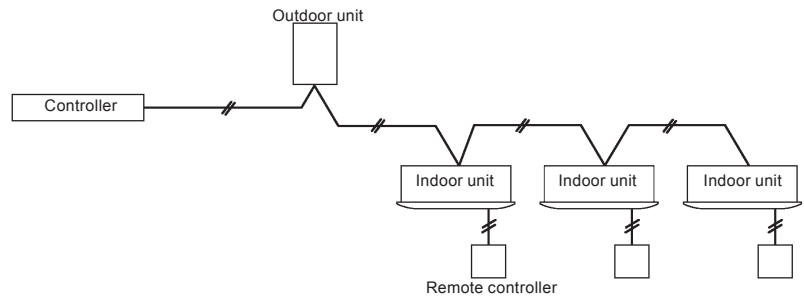

Figure 11

(5) Indoor unit check

① Remove the securing part

- When installing the 4-way ceiling cassette type, check that the protective tapes has been removed. (Figure 12) removed.
- For the ceiling suspended type or wall mounted type, check that the part securing the auto flap has been removed.

Caution
Operating the indoor unit while a securing part is attached may result in the generation of an abnormal noise, and the operation of a protection device.

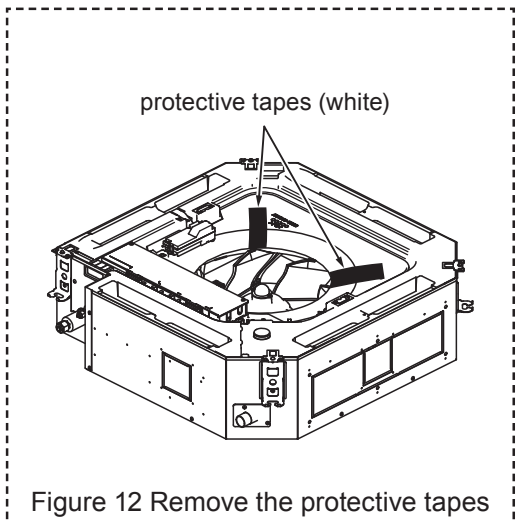

Figure 12 Remove the protective tapes

II. Preparations and Test Run Procedures

IMPORTANT!

Read Before Starting

This air conditioning system meets strict safety and operating standard. As the installer or service person, it is an important part of your job to install or service the system so it operates safely and efficiently.

For safe installation and trouble-free operation, you must:

- Carefully read this instruction booklet before beginning.
- Follow each installation or repair step exactly as shown.
- Observe all local, state, and national installation codes.
- Pay close attention to all warning and caution notices given in this manual.



WARNING

This symbol refers to a hazard or unsafe practice which can result in severe personal injury or death.



CAUTION

This symbol refers to a hazard or unsafe practice which can result in personal injury or product or property damage.

If Necessary, Get Help

These instructions are all you need for most installation sites and maintenance conditions. If you require help for a special problem, contact our sales/service outlet or your certified dealer for additional instructions.

In Case of Improper Installation

The manufacturer shall in no way be responsible for improper installation or maintenance service, including failure to follow the instructions in this document.

SPECIAL PRECAUTIONS

WARNING When Wiring



ELECTRICAL SHOCK CAN CAUSE SEVERE PERSONAL INJURY OR DEATH. ONLY A QUALIFIED, EXPERIENCED ELECTRICIAN SHOULD ATTEMPT TO WIRE THIS SYSTEM.

- Do not supply power to the unit all wiring and tubing are completed or reconnected and checked.
- Highly dangerous electrical voltage are used in this system. Carefully refer to the wiring diagram and these instructions when wiring. Improper connections and inadequate grounding can cause **accidental injury or death**.
- The unit must be connected to the earth according to local electrical code.
- Connect all wiring tightly. Loose wiring may cause overheating at connection points and a possible fire hazard.

When Transporting

Be careful when picking up and moving the indoor and outdoor units. Get a partner to help, and bend your knees when lifting to reduce strain on your back. Sharp edges or thin aluminum fins on the air conditioner can cut your fingers.

When Installing...

...In a Ceiling or Wall

Make sure the ceiling/wall is strong enough to hold the unit's weight. It may be necessary to construct a strong wood or metal frame to provide added support.

...In a Room

Property insulate any tubing run inside a room to prevent "sweating" that can cause dripping and water damage to walls and floors.

...In Moist or Uneven Locations

Use a raised concrete pad or concrete blocks to provide a solid, level foundation for the outdoor unit. This prevents water damage and abnormal vibration.

...In an Area with High Winds

Securely anchor the outdoor unit down with bolts and a metal frame. Provide a suitable air baffle.

...In a Snowy Area (for Heat Pump-type Systems)

Install the outdoor unit on a raised platform that is higher than drifting snow. Provide snow vents.

When Connecting Refrigerant Tubing

- Use the flare method for connecting tubing.
- Apply refrigerant lubricant to the matching surfaces of the flare and union tubes before connecting them, then tighten the nut with a torque wrench for a leak-free connection.
- Check carefully for leaks before starting the test run.

When Servicing

- Turn the power OFF at the main power box (mains) before opening the unit to check or repair electrical parts and wiring.
- Keep your fingers and clothing away from any moving parts.
- Clean up the site after you finish, remembering to check that no metal scraps or bits of wiring have been left inside the unit being serviced.

Others



CAUTION

- Ventilate any enclosed areas when installing or testing the refrigeration system. Escaped refrigerant gas, on contact with fire or heat, can produce dangerously toxic gas.
- Confirm upon completing installation that no refrigerant gas is leaking. If escaped gas comes in contact with a stove, gas water heater, electric room heater or other heat source, it can produce dangerously toxic gas.

NOTICE

- The English text is the original instructions. Other languages are translation of the original instructions.

SAFETY PRECAUTIONS



WARNING

- **Check the type of gas used for engine fuel.**
If the wrong type of gas is supplied, the engine can suffer combustion problems, and there is the danger of poisoning caused by exhaust gases.



WARNING

- **Check the following before performing a test run.**
 - Ensure that tube connections are securely attached, and that there are no leaks.
 - Ensure that shut-off valves (service valves) are open. If a compressor is run while a shut-off valve (service valve) is closed, the pressure will become abnormally high and there is a risk of damage to the parts of the compressor, etc. Additionally, if there is a leak in the connection parts, the pressure will become even more abnormally high because of sucked-in air, etc. and there is a risk of rupturing and injury.

Important Information Regarding the Refrigerant Used

This product contains fluorinated greenhouse gases. Do not vent gases into the atmosphere.

Refrigerant type: R410A

GWP⁽¹⁾ value: 2088

⁽¹⁾ GWP = global warming potential

Periodical inspections for refrigerant leaks may be required depending on European or local legislation. Please contact your local dealer for more information.

1. Precautions

Using the level, check that the installation of the outdoor unit is horizontal. If not, this may result in failure.

To operate the system, individual addresses must be set for the outdoor and indoor units.

The outdoor unit address must be set manually; however, the indoor unit addresses are set automatically for each refrigerant system.

After the addresses are set, the indoor unit addresses must be checked in order to identify each indoor unit.

After the addresses have been checked, apply unit number labels to each indoor unit and outdoor unit. These will be necessary for later maintenance.

Follow the procedure below and perform the work correctly.

2. Test Run Procedure

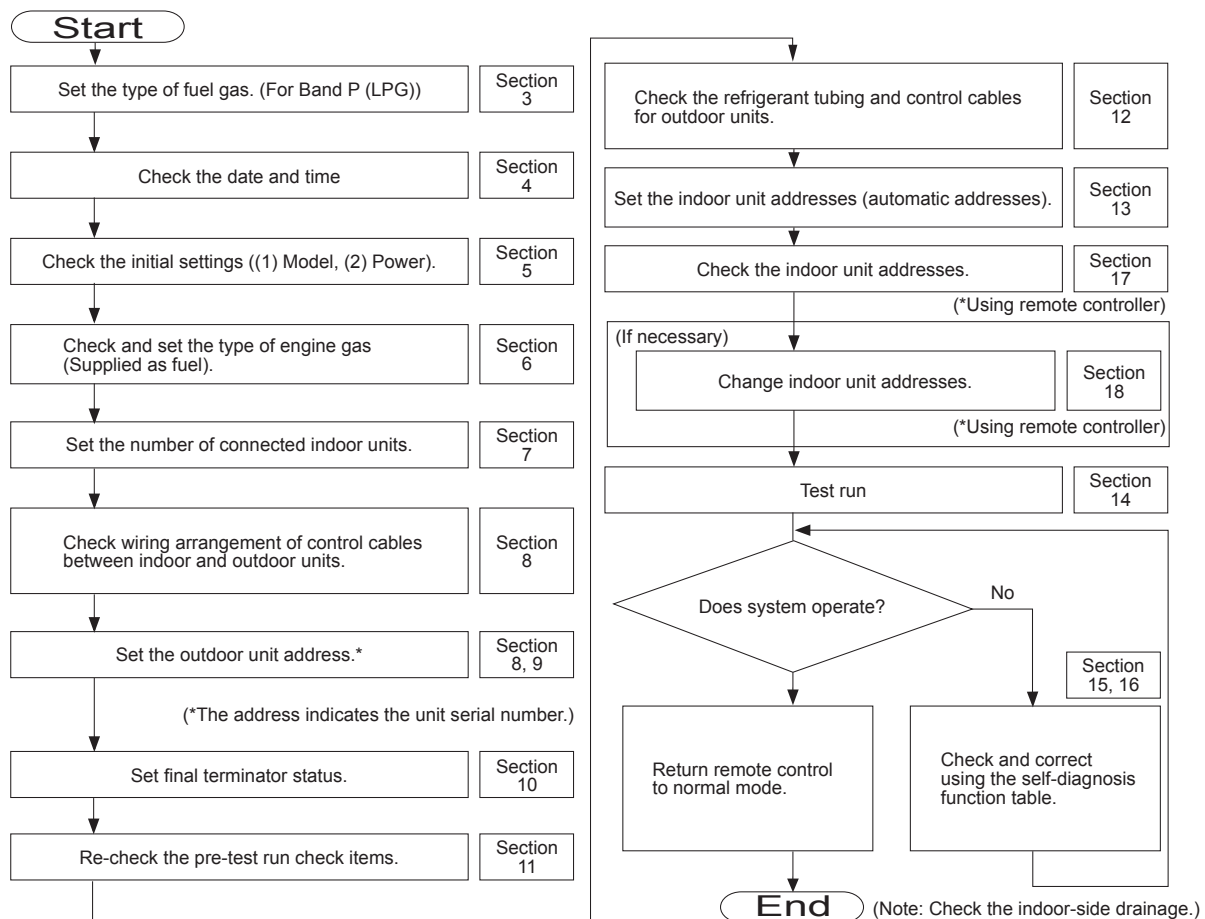

GHP outdoor unit control board

2-1. Display and settings using the keys

- Essentially all display and setting operations can be completed using the UP, DOWN, and SET keys.
- Information is displayed with a 6-digit, 7-segment LED.
- Pressing the HOME key at any time returns to normal display.

2-2. Basic key operations

- To select a menu item, use the UP and DOWN keys to display the item, then press the SET key to select it.
- To change a setting value, use the UP and DOWN keys to display the new value, then press the SET keys to confirm it.
- If the SET key is pressed and held for 1 second while operation data is displayed, the setting mode is canceled.

2-3. Selecting a setting item

- (1) Press the UP and DOWN keys to display the menu item to set. (During and after menu item change, the menu item number is displayed for approximately 1 second, and then the status/setting is displayed.)
- (2) After the menu item is displayed, press the SET key to select that item.
 - * The HOME key can be pressed at any time to return to the n a . 0 0 . menu item. In this case, change to settings that were in progress are lost. In addition, if there are no operations for a period of 10 minutes while any menu item other than n a . 0 0 . is displayed, the display automatically return to the n a . 0 0 . menu item and any changes to settings that were in progress are lost.

Table 1

	Menu item	Status/setting display	Menu item contents
DOWN ↑ ↓ UP	n a . 0 0 .	u 0 1 0 2 0	Display operating data (Usual display)
	n a . 0 1 .	0 0 0 A 0 0	Display trouble data (Reset trouble; display history)
	n a . 0 2 .	a 1 0 0 0 0	Display oil change timing (Clear change time; add oil)
	n a . 0 3 .	d 5 6 0 3	Display model (Set speed)
	n a . 0 4 .	E E 5 E	Force test run setting for outdoor unit (Open valve; water circulation; close bypass valve)
	n a . 0 5 .	5 E E a u E	Set outdoor unit
	n a . 0 6 .	5 E E , n	Set indoor unit
	n a . 0 7 .	5 E E G E	Set generator
	n a . 0 8 .	5 E E r P n	Force engine speed setting
	n a . 0 9 .	, n 5 E 5	Display indoor unit status
	n a . 1 0 .	F , r 5 E	Initial settings (address, number of indoor units, engine gas type)
n a . 1 1 .	1 7 0 4 0 1	Date display (time display, clock display)	

U-20GES3E5 outdoor unit control board

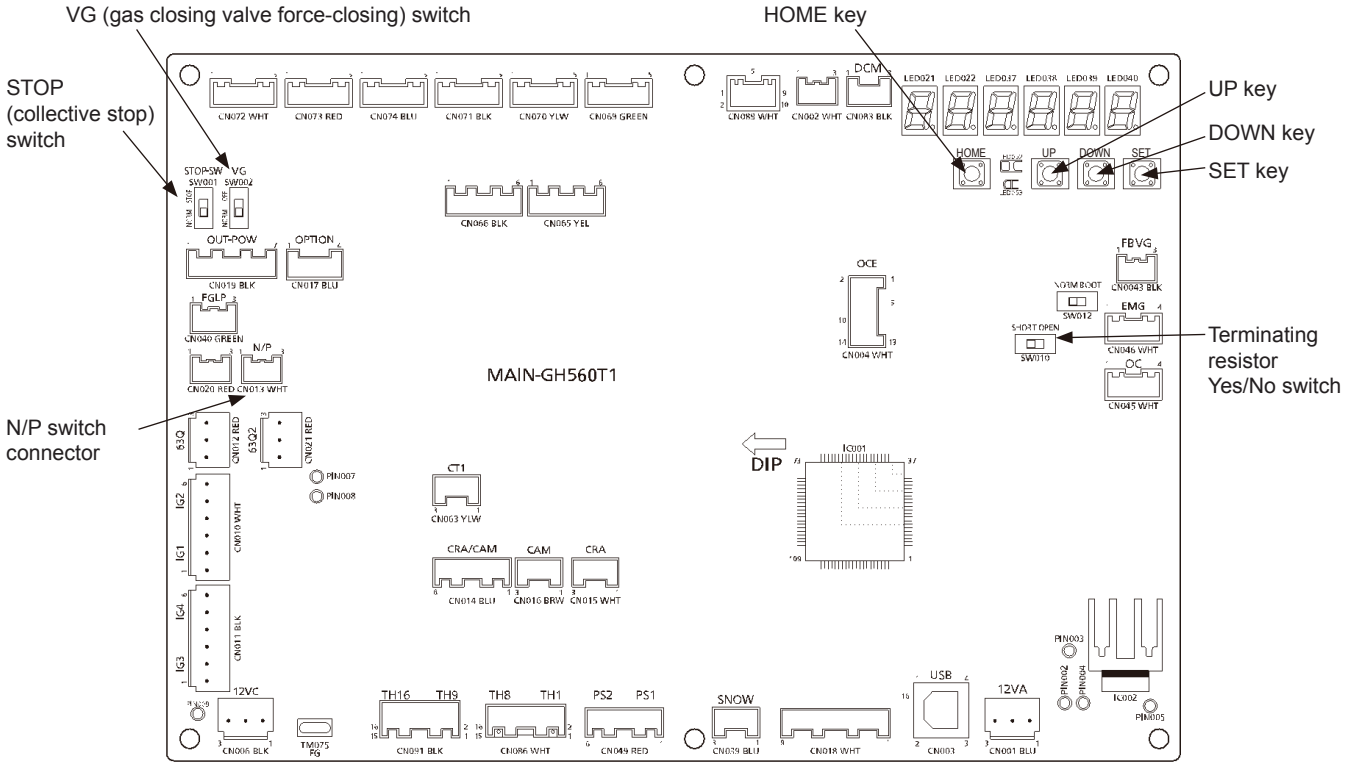

Fig. 1

U-10MES2E8 outdoor unit control board

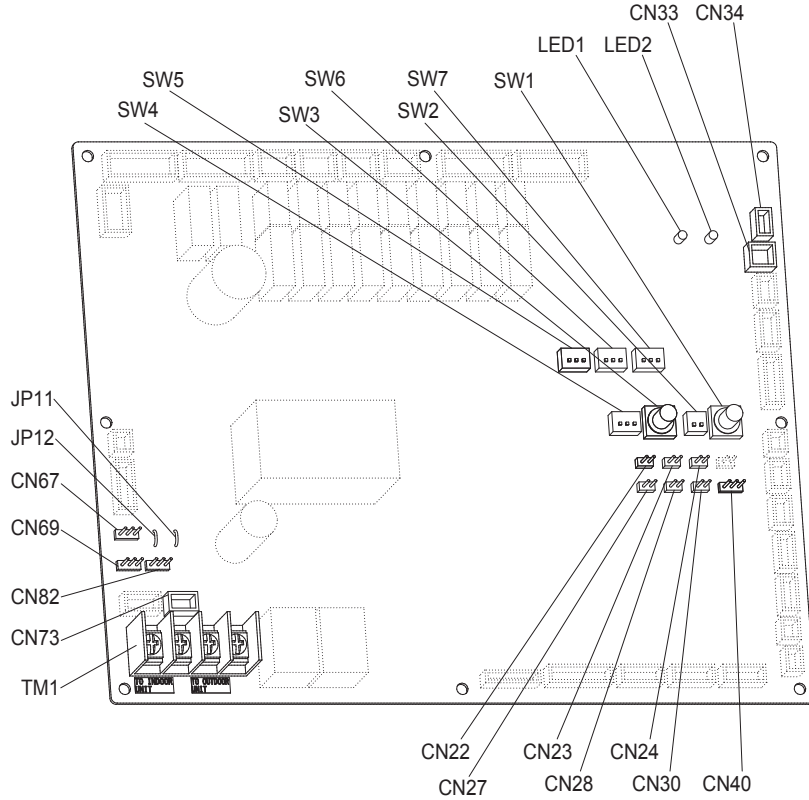

Fig. 2

Table 2 Name and function of each switch on U-10MES2E8 outdoor unit control P.C.board

Function switch	Remarks
RC plug (3P, BLU) (CN73)	Connects to outdoor unit maintenance remote controller and content of alarm message will be checked.
AP pin (2P, WHT) (CN24)	Can be used when vacuuming the outdoor unit.
SNOW plug (3P, RED) (CN34)	Can be used when installing a snowfall sensor device.
SILENT plug (2P, WHT) (CN33)	Can be used when setting the outdoor unit fan in sound absorbing mode.
OC EMG terminal (3P, BLK) (CN69)	If "TO INDOOR UNIT" accidentally connected to high voltage, use the terminal base TM1. Method: 1. Replace the pins 1 and 2 of CN69 with the pins 2 and 3. 2. Disconnect J 1.
RC1 EMG terminal (3P, BLK) (CN82)	If "TO OUTDOOR UNIT" accidentally connected to high voltage, use the terminal base TM1. Method: 1. Replace the pins 1 and 2 of CN82 with the pins 2 and 3. 2. Disconnect JP1

3. Setting the Fuel Gas Type (If Band P (LPG) is Used)

- * When using Band P (LPG) for fuel gas, the gas type has to be configured.
- * The outdoor unit power breaker remains OFF.

- (1) Move the lever of the N/P switch that is attached to the mixer part of the engine to the position shown in the diagram. Turn it 180 degrees in the anticlockwise direction (there is a stopper provided). Do not apply unnecessary force to turn it any further.



CAUTION

After installing, be sure to check that there is no gas leakage. There is the danger of fire if gas leaks

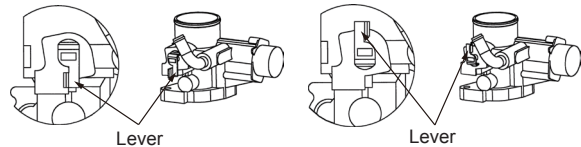

Lever
When shipping

Lever
When the Band P (LPG) is setting

Fig. 3

- (2) Mount the attached short-circuit connector to the N/P switch (Fig. 1) of the outdoor control board.
* Switch on the power breaker of the outdoor unit.

- (3) Apply the < Gas type set and adjusted > label in the PL NAME designated location in the electrical box.

- (4) After making the setting, use an ink pen or other tool to make a mark so that the original setting position of the lever is known.

4. Checking the Date and Time in the GHP outdoor unit

● Checking

- (1) Select the (date display) menu item to display the current date.

Example: (April 1, 2018)

- (2) With the date displayed, press the SET key to switch to the time display.

Example: (11 h 05 m 25 s)

- (3) With the time displayed, press the SET key to switch back to the date display.

* If the current date and time display are not correct, reset (correct) them.

● Setting (correcting)

- (1) With the date or time displayed, press and hold the SET key for 1 second to enter setting mode.

Example: (2018)

- (2) Each time the SET key is pressed, the setting contents are confirmed and the first digit display changes. The settings are as shown in Table 3. After is displayed for the first digit, the display returns to .

Table 3

First digit display	Contents	Sample setting/status display	Display meaning
1.	Year	1. 1 8	18 (Year 2018)
2.	Month	2. 4	April
3.	Day	3. 1	First day of the month
4.	Hour	4. 1 1	11 AM
5.	Minutes/seconds	5. 6	6th minute after the hour

(3) For each display, the value can be changed by pressing the UP and DOWN keys.

When the SET key is pressed for display 5., the seconds are reset to zero.

(4) Press the HOME key to end the setting process.

* Depending on the connected system and control device, the date and time may be set automatically.

5. Checking the Initial Settings in the GHP outdoor unit

(1) Select the **n a i 0.** (initial settings) menu item to display **F i r s t.**

(2) Press the SET key to display the following:

Example: **o u t 0 1** (system address setting)

(3) With this display, press the UP and DOWN keys to select settings including those for system address, outdoor unit address, number of connected outdoor units, number of connected indoor units, model, gas type, and automatic address startup.

Table 4

	Status/setting display	Function
↑ DOWN ↓ UP	o u t 0 1	System address setting
	s u b 0 0	Outdoor unit address setting
	o n 0 1	Number of connected outdoor units setting
	i n 0 1	Number of connected indoor units setting
	5 6 0.3	Model setting (non-modifiable)*1
	G A S 0 1	Gas type setting
	r e f 0 1	Refrigerant setting (non-modifiable)*1
	G E n 0 3	Generator (setting disabled)*1
	L - C 0 0	Model 1 setting (non-modifiable)*1
	2 - 3 0 5	Model 2 setting (non-modifiable)*1
	F o r 0 0	Destination setting (non-modifiable)*1
	o y u 0 0	Hot water setting
	o i l 0 0	Oil change time display
	s o u 0 1	Single phase setting (non-modifiable)*1
	P i P E	Tube connection check (Use for W Multi)*2
	H A d d 0	Heat automatic address setting
C A d d 0	Cool automatic address setting	

*1: Although the value varies depending on the model, do not change.

*2: Do not change except the W Multi model.

6. Checking and Setting the Fuel Gas Type in the GHP outdoor unit

* It is necessary to check and set the “gas type” setting for this unit.

If Band P (LPG) is used, check that section 3 has been set.

- (1) Select the (initial settings) menu item to display .
- (2) Use the UP and DOWN keys to select the gas type setting.
Example: .
- (3) To change the setting, press and hold the SET key for 1 second.
(During this time, the setting in progress indicator lights.)
- (4) Use the UP and DOWN keys to select the gas type.
Example: When is displayed, pressing the UP key displays .

Table 5

	Status/setting display	Type of gas	Status/setting display	Type of gas
↑ DOWN ↓ UP	<input type="text" value="G A 6 0 0"/>	Band P (LPG)	<input type="text" value="G A 6 0 8"/>	No Use
	<input type="text" value="G A 6 0 1"/>	No Use	<input type="text" value="G A 6 0 9"/>	No Use
	<input type="text" value="G A 6 0 2"/>	Band H/L (Natural Gas)	<input type="text" value="G A 6 0 A"/>	No Use
	<input type="text" value="G A 6 0 3"/>	No Use	<input type="text" value="G A 6 0 b"/>	No Use
	<input type="text" value="G A 6 0 4"/>	Band E (Natural Gas)	<input type="text" value="G A 6 0 C"/>	No Use
	<input type="text" value="G A 6 0 5"/>	No Use	<input type="text" value="G A 6 0 d"/>	No Use
	<input type="text" value="G A 6 0 6"/>	No Use	<input type="text" value="G A 6 0 E"/>	Band LNG (Natural Gas)
	<input type="text" value="G A 6 0 7"/>	No Use	<input type="text" value="G A 6 0 F"/>	No Use

(5) Press and hold the SET key for 1 second. (TEST/WARNING turns off.)

(6) Press the HOME key to end the setting process.

- IF Band P (LPG) is used, follow the procedure above to change the setting to in .

7. Setting the Number of Connected Indoor/Outdoor Units in the GHP outdoor unit

* Set the number of connected indoor/outdoor units on the GHP outdoor unit control board.

* When setting the number of indoor/outdoor units connected, count only units connected within the same refrigerant tubin system.

* The number of units is set to “1” at the time of shipment.

Number of connected outdoor units

- (1) Select the (initial settings) menu item to display .
- (2) Use the UP and DOWN keys to select the setting for the number of connected outdoor units.
Example: (Number of connected outdoor units is 1.)
- (3) To change the setting, press and hold the SET key for 1 second.
(During this time, the setting in progress indicator lights.)
- (4) Use the UP and DOWN keys to select the number of connected units.
Example: If is displayed, pressing the UP key displays .
- Set to for the U-20GES3E5.
- (5) Press and hold the SET key for 1 second. (TEST/WARNING turns off.)
- (6) Press the HOME key to end the setting process.

Number of connected indoor units

- (1) Select the (initial settings) menu item to display .
- (2) Use the UP and DOWN keys to select the setting for the number of connected indoor units.
Example: (Number of connected indoor units is 1.)

- (3) To change the setting, press and hold the SET key for 1 second.
(During this time, the setting in progress indicator lights.)
- (4) Use the UP and DOWN keys to select the number of connected units.
Example: If is displayed, pressing the UP key displays .
- The setting range is 1 – 48 units (- .
- (5) Press and hold the SET key for 1 second. (TEST/WARNING turns off.)
- (6) Press the HOME key to end the setting process.

8. Setting the System Address and Outdoor Unit Address in the GHP outdoor unit

- * Set the addresses on the GHP outdoor unit control board.
- * The system address is set to “1” at the time of shipment.

● Setting the address

- (1) Check the wiring condition of the indoor/outdoor control cables.

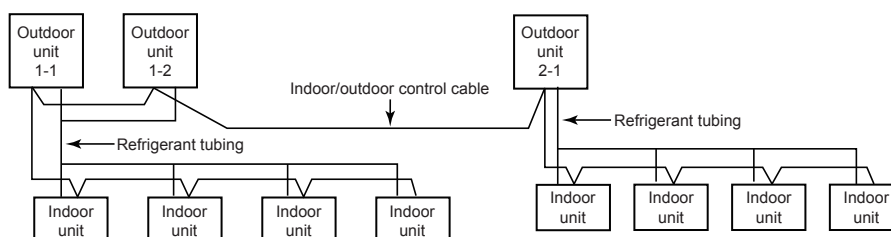

Fig. 4

- (2) Set the system address.
 1. Select the (initial settings) menu item to display .
 2. Use the UP and DOWN keys to select the system address setting.
Example: (System address is 1.)
 3. To change the setting, press and hold the SET key for 1 second.
(During this time, the setting in progress indicator lights.)
 4. Use the UP and DOWN keys to select the system address.
Example: If is displayed, pressing the UP key displays .
 - The setting range is 1 – 30 (- .
 5. Press and hold the SET key for 1 second. (TEST/WARNING turns off.)
 6. Press the HOME key to end the setting process.

- (3) Set the outdoor unit address.
 1. Select the (initial settings) menu item to display .
 2. Use the UP and DOWN keys to select the outdoor unit address setting.
Example: (Outdoor unit address is 1.)
 3. To change the setting, press and hold the SET key for 1 second.
(During this time, the setting in progress indicator lights.)
 4. Use the UP and DOWN keys to select the outdoor unit address.
Example: If is displayed, pressing the UP key displays .
 - Set to for the U-20GES3E5.
 5. Press and hold the SET key for 1 second. (TEST/WARNING turns off.)
 6. Press the HOME key to end the setting process.

9. Settings for the unit number setting, number of outdoor units, number of indoor units, and system addresses on the U-10MES2E8

Set the unit number setting, number of outdoor units, number of indoor units, and system addresses on the outdoor unit control board for the U-10MES2E8.

● Unit number setting

Set No.2 unit for the U-10MES2E8.

Only switch 2 of the unit number setting DIP switch SW5 (a 3P DIP switch) should be set to ON.

Unit No. setting	Address setting of outdoor unit (SW5) (3P DIP switch)
Unit No. 2	2 ON 

● Setting the number of outdoor units









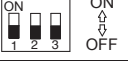

On the U-10MES2E8, all three switches 1~3 of the number of outdoor units setting DIP switch SW6 (a 3P DIP switch) should be set to ON.

Outdoor unit setting (SW6) (3P DIP switch)	
All ON	

● Setting the number of indoor units

Use the indoor units setting switches SW4 (a 3P DIP switch) and SW3 (a Rotary switch RED) to set the number of connected indoor units.







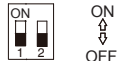

Example settings for the number of indoor units

No. of indoor units	Indoor unit setting (SW4) (3P DIP switch) 10 20 30	Indoor unit setting (SW3) (Rotary switch RED)
1 unit (factory setting)	All OFF 	 Set to 1
11 units	1 ON 	 Set to 1
21 units	2 ON 	 Set to 1
31 units	3 ON 	 Set to 1
48 units	1 & 3 ON 	 Set to 8

● Setting the system addresses

Set the same system address as the GHP outdoor unit that is on the same refrigerant system.

Use the system address switch SW2 (a 2P DIP switch) and system address SW1 (a Rotary switch BLK) to set system addresses.

System address No.	System address (SW2) (2P DIP switch) 10 20	System address (SW1) (Rotary switch BLK)
System 1 (factory setting)	Both OFF 	 Set to 1
System 11	1 ON 	 Set to 1
System 21	2 ON 	 Set to 1
System 30	1 & 2 ON 	 Set to 0

10. Setting Terminator Status

- The terminating resistance of the indoor/outdoor operation lines should have 1 location set to “with resistance” [SHORT] if there is 1 refrigerant system. If there are 2 or more refrigerant systems, set 2 locations to “with resistance” [SHORT]. If 2 locations are set to “with resistance”, set the 2 terminating resistances for the outdoor unit nearest to the central control device, and for the one furthest away, to “with resistance” [SHORT], and all other outdoor units to “without resistance” [OPEN]. This is to stabilize communications. Setting 3 or more locations to “with resistance” is prohibited.
- If the terminating resistance of an outdoor unit for a multi-system of U-20GES3E5 and U-10MES2E8 is set to “with resistance” [SHORT], set the outdoor unit of the gas heat pump air conditioner to “with resistance” [SHORT], and set the outdoor unit of the U-10MES2E8 to “without resistance” [OPEN].

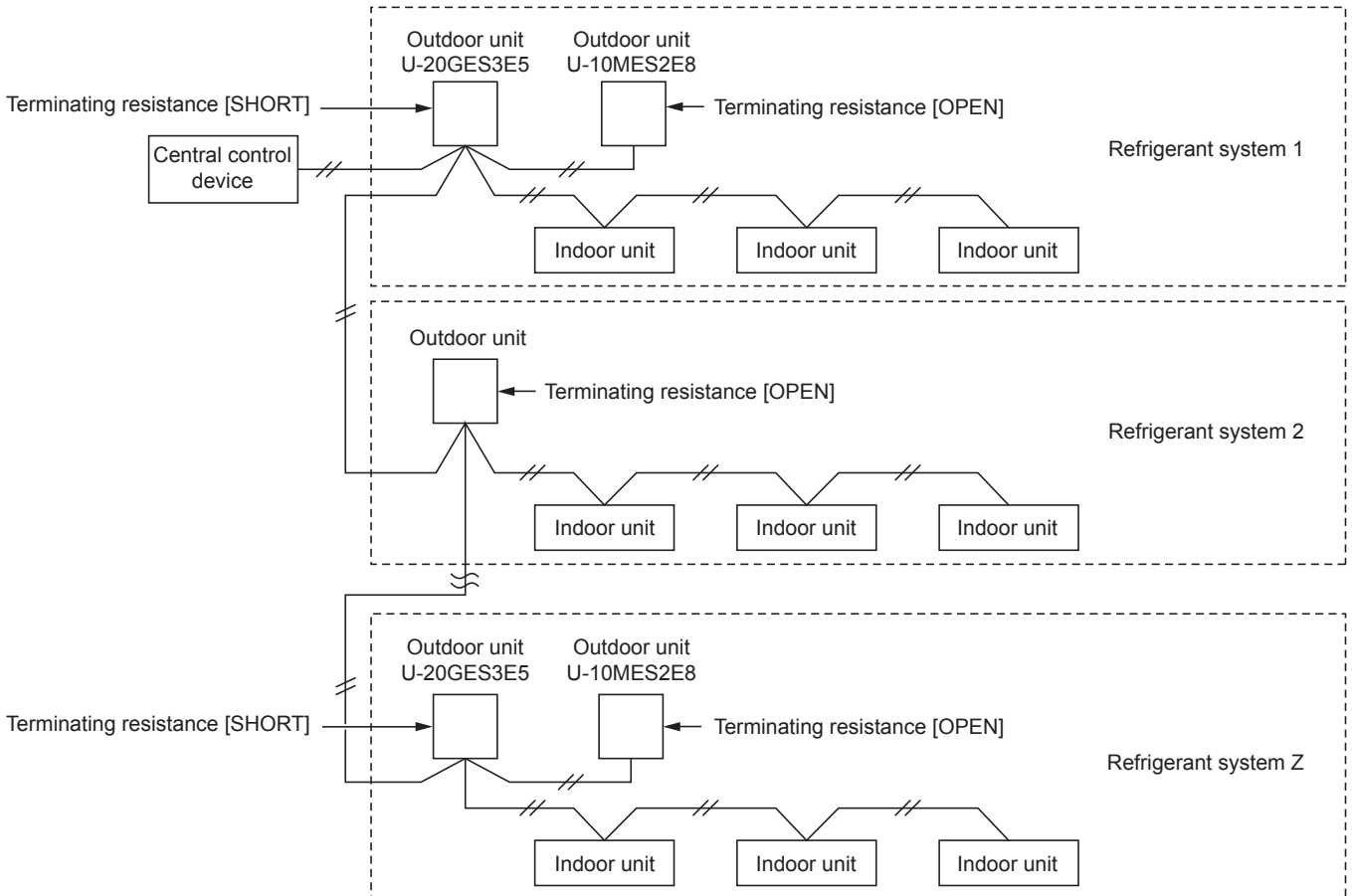

Fig. 5

- The terminating resistance for the gas heat pump air conditioner is set using DIP switch SW010 on the outdoor main circuit board.
- The terminating resistance for the U-10MES2E8 is set by switching the shorted socket of the terminating resistance pin (3P) (CN67) of the outdoor unit control board.

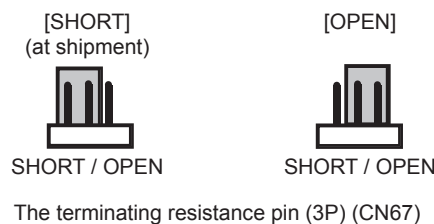

Fig. 6

11. Items to Check before the Test Run

- (1) In order to activate the crankcase heater, turn the remote power switch on at least 5 hours before starting operation.
(If this is not done, the compressor may be damaged.)
- (2) Fully open the shut-off valves of the gas, liquid and balance tubes of the GHP outdoor unit. Turn the valves slowly through 90° to the left (counterclockwise). The valve is fully open when it reaches the stopper position. Do not attempt to force it past that point. Note that the orientation of the tabs on the shut-off valves of the GHP outdoor unit for the gas and liquid tubes is 90° different from the balance tubes. (Fig.7)
- (3) Fully open the shut-off valves of the gas, liquid and balance tubes of the U-10MES2E8 outdoor unit. The gas tube shut-off valve is fully opened by turning it fully to the left, using a hexagonal wrench (8mm across faces). The liquid tube shut-off valve is fully opened by turning it fully to the left, using a hexagonal wrench (4mm across faces). Turn the shut-off valve of the balance tube slowly through 90° to the left (counterclockwise). The valve is fully open when it reaches the stopper position. Do not attempt to force it past that point. (Fig.8)
- (4) Check that the cardboard and Styrofoam that were used for transport have been removed from the indoor fan and the automatic flap.

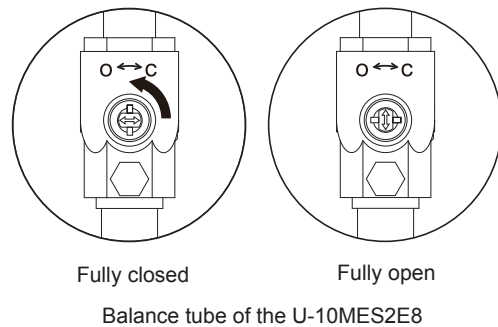
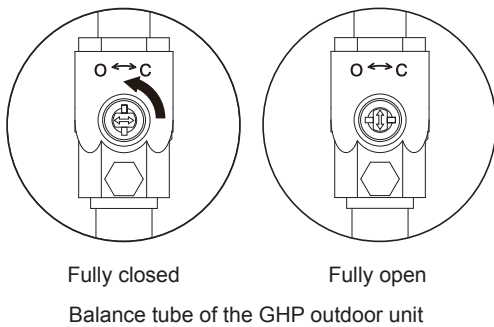
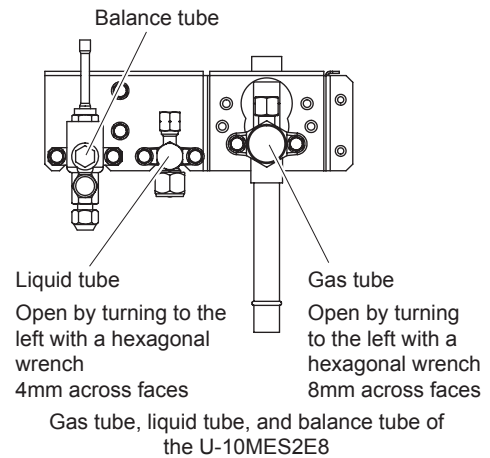
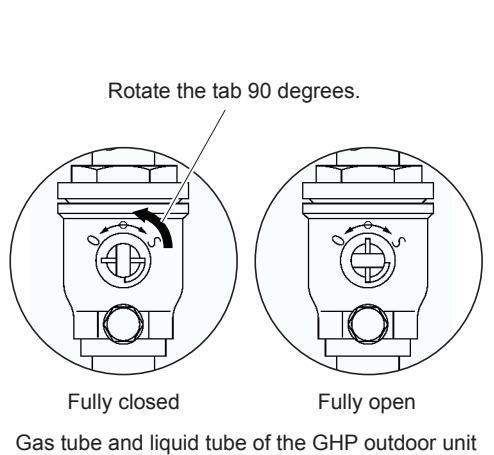

Fig. 7

Fig. 8

Basic wiring diagram: Case 2

If the indoor/outdoor control cables are connected to other W Multi units or 3WAY Multi outdoor units (linked wiring)

- Make sure the outdoor units are operating.
- Perform the procedure for automatic address setting using the outdoor unit with the smallest address.
(See the sections on automatic address setting below.)

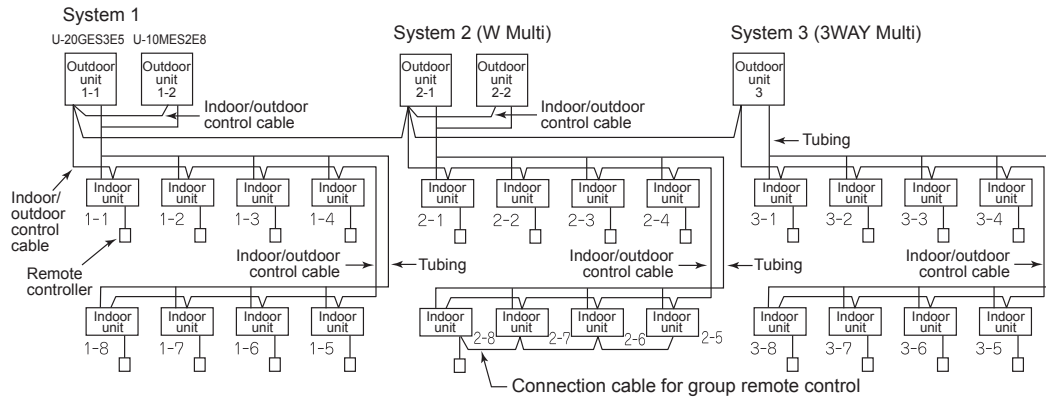

Fig. 10

- Set the indoor unit addresses using one of the following methods, depending on wiring configurations for the power cables.

Case 1 If the power can be turned on separately for each refrigerant tubing system

- Indoor unit addresses can be set without actually running the outdoor units (however, their power must be on).
 - (1) Select the (initial settings) menu item to display on the outdoor unit (with the smallest address) in the refrigerant tubing system for which you want to set addresses.
 - (2) Use the UP and DOWN keys to select the automatic address setting with heating operation ().
 - (3) Press and hold the SET key for 1 second.
The setting in progress indicator light, and automatic address setting begins.
When the indicator turns off, automatic address setting is completed.
 - (4) Turn on the power for the next system (this system should be the only system turned on), and perform steps (1) to (3) above.
 - (5) Repeat the above steps until automatic address setting is finished for all the indoor units.

Case 2 If the power cannot be turned on separately for each refrigerant tubing system

- In this case, automatic address setting is performed with the indoor and outdoor units operating. Be sure to complete the refrigerant tubing work and fuel piping work before setting the addresses.
- Set SW002 (VG) and SW001 (STOP SW) on the outdoor unit control board to "NORM". If these switches are set to "OFF" or "STOP", the engine will not start.

<Automatic address setting with heating operation>

- (1) Turn on power to all systems.
- (2) Select the (initial settings) menu item to display on the outdoor unit (with the smallest address) in the refrigerant tubing system for which you want to set addresses.
- (3) Use the UP and DOWN keys to select the automatic address setting with heating operation ().
- (4) Press and hold the SET key for 1 second.
The setting in progress indicator light, and automatic address setting begins.
When the indicator turns off, automatic address setting is completed.
- (5) Perform steps (2) to (4) above on the outdoor unit in the next system.
- (6) Repeat the above steps until automatic address setting is finished for all the indoor units.

* The status of automatic address setting is displayed as follows.

Example: **H R d d 0** (ready to start automatic address setting)

The meanings for the last digits displayed are as follows.

- 0**: Ready to start automatic address setting
- 1**: Waiting for indoor unit automatic address preparation
- 2**: Engine running
- 3**: Checking indoor units
- 4**: Setting addresses
- 5**: Setting completed

* To cancel automatic address setting with heating operation before it is completed, press and hold the SET key for 1 second.

The setting in progress indicator will turn off.

* If automatic address setting is not successful with heating operation, follow the procedure below to perform automatic address setting with cooling operation.

<Automatic address setting with cooling operation>

- (1) Turn on power to all systems.
- (2) Select the **n a i 0 . . .** (initial settings) menu item to display **F r 6 E** on the outdoor unit (with the smallest address) in the refrigerant tubing system for which you want to set addresses.
- (3) Use the UP and DOWN keys to select the automatic address setting with cooling operation (**E R d d 0**).
- (4) The remaining procedure is the same as steps (4) to (6) above.

* If automatic address setting is not successful with engine operation, refer to "Manual address setting" to set the addresses.

<Manual address setting> Perform the following using the remote controller.

<<Setting the system addresses>>

- (1) Press the **↵**, **CANCEL**, and **SET** buttons simultaneously for at least 4 seconds to enter the advanced setting mode and display "CODE No. **i 0**".
- (2) Press the **▲** or **▼** temperature adjustment buttons to display "CODE No. **i 2**" (system addresses).
- (3) Press the **▲** or **▼** time adjustment buttons to change "SET DATA" to the desired system address.
0 0 0 1 → **0 0 0 2** → ... **0 0 3 0** can be displayed in "SET DATA".
- (4) Press the **SET** button to confirm the setting. (The display stops blinking and remains lit.)

<<Setting indoor unit addresses>>

- (5) Press the **▲** or **▼** temperature adjustment buttons to display "CODE No. **i 3**" (indoor unit addresses).
- (6) Press the **▲** or **▼** time adjustment buttons to change "SET DATA" to the desired indoor unit address.
0 0 0 1 → **0 0 0 2** → ... **0 0 6 4** can be displayed in "SET DATA".

CAUTION: Do not set the address to a value larger than the number of indoor units configured on the outdoor unit (see Section 7). In addition, do not use the same address for units within a common refrigerant system.

- (7) Press the **SET** button to confirm the setting. (The display stops blinking and remains lit.)
- (8) Finally, press the **↵** button to return the remote controller to standard mode.

14. Test Run Settings

* When a test run is performed using the control board of the outdoor unit with the smallest address, the test run is performed for all outdoor units connected to the same refrigerant tubing system.

* In a multi-system containing a U-20GES3E5 and a U-10MES2E8, make test run settings from the outdoor unit control board of the GHP outdoor unit.

* You can cancel a test run from the control board of the outdoor unit with the smallest address.

(1) Select the (test run, forced outdoor unit operation setting) menu item to display .

(2) Press the SET key to change to the following display.

Example: (forced cool test run setting)

(3) Use the UP and DOWN keys to select the following settings: forced cool test run, forced heat test run, forced valve operation, forced water circulation, and forced bypass valve closing.

Table 6

	Display	Function
↑ DOWN ↓ UP	<input type="text" value="000000"/> (C O O L)	Forced cool test run (GHP and EHP)
	<input type="text" value="00 H E A T"/> (H E A T)	Forced heat test run (GHP and EHP)
	<input type="text" value="00 C O O L"/> (C O O L)	Forced cool test run (GHP priority)
	<input type="text" value="00 H E A T"/> (H E A T)	Forced heat test run (GHP priority)
	<input type="text" value="00 E C O O L"/> (E C O O L)	Forced cool test run (EHP priority)
	<input type="text" value="00 E H E A T"/> (E H E A T)	Forced heat test run (EHP priority)
	<input type="text" value="00 V O P E N"/> (V O P E N)	Forced valve opening (GHP)
	<input type="text" value="00 P U N P"/> (P U N P)	Forced water circulation (GHP)
	<input type="text" value="00 U C L O S E"/> (U C L O S E)	Forced bypass valve closing (GHP)
	<input type="text" value="00 A R R"/> (A R R)	Automatic air release mode (GHP)

GHP: Gas heat pump air conditioner, EHP: Electrical heat pump air conditioner (U-10MES2E8)

14-1. Setting outdoor unit test run and forced GHP outdoor unit operation

Forced cool test run setting

- With the forced cool test run setting selected, press and hold the SET key for 1 second to perform a forced cool test run. When using (GHP priority) or (EHP priority), the prioritized outdoor unit operates, but the other unit may also operate in some cases. During this time, the setting in progress indicator lights.

Forced heat test run setting

- With the forced test run setting selected, press and hold the SET key for 1 second to perform a forced heat test run. When using (GHP priority) or (EHP priority), the prioritized outdoor unit operates, but the other unit may also operate in some cases. During this time, the setting in progress indicator lights.

Forced valve opening (Use when applying vacuum.)

- With the forced valve opening setting selected, press and hold the SET key for 1 second to operate the valves. The indoor unit solenoid valve, outdoor unit solenoid valves (2), liquid valve, and bypass valve open all the way. During this time, the setting in progress indicator lights.
- If the valve of the EHP outdoor unit (U-10MES2E8) is opened, use the AP pin (2P, WHT) (CN24) of the EHP outdoor unit control board.

Forced water circulation setting (Use when checking the cooling water system.)

- With the forced water circulation setting selected, press and hold the SET key for 1 second to operate the cooling water pump. (The cooling water 3-way solenoid valve switches to the radiator side for 3 minutes, then to the sub evaporator side for 1 minute 15 seconds.) During this time, the setting in progress indicator lights.

Forced bypass valve closing (Use when performing pump-down.)

- With the forced bypass valve closing setting selected, press and hold the SET key for 1 second to close the bypass valve all the way. During this time, the setting in progress indicator lights.

Automatic air-bleeding mode (Used for the cooling water system, air bleeding and so on.)

- While the automatic air-bleeding mode is selected, press and hold the SET key for a second to operate the cooling water pump, move the cooling water three-way valve and warm water three-way valve to automatically conduct the air-bleeding operation. The cooling water pump automatically repeats via start and stop. At the same time, the TEST/WARNING indication lights up and the progress status is displayed.

* Mount the air-bleeding jig before conducting this operation

* After this operation, check for the presence or absence of residual air with the forced water circulation setting. If air-bleeding is insufficient, repeat this operation until all the air has come out.

Canceling forced settings

- To cancel a forced setting, press and hold the SET key for 1 second while the forced setting is selected. The setting in progress indicator turns off, and operation returns to forced setting selection.

15. Diagnostic Self-Check List (GHP)

Table 7

System A (activation of engine system operation devices)

Outdoor unit control board display	Contents
A 0 0	Operation is normal
A 0 1	Engine oil pressure trouble
A 0 2	Engine oil trouble
A 0 3	Engine speed too high
A 0 4	Engine speed too low
A 0 5	Ignition power trouble
A 0 6	Engine start failure
A 0 7	Fuel gas valve failure
A 0 8	Engine stall
A 1 0	Exhaust gas temp. high
A 1 1	Engine oil level trouble
A 1 2	Throttle failure
A 1 4	Engine oil pressure switch failure
A 1 5	Start power output short circuit

Outdoor unit control board display	Contents
A 1 6	Starter locked
A 1 7	CT trouble (starter current detection failure)
A 1 9	Cooling water temp. low
A 2 0	Cooling water temp. high
A 2 1	Cooling water level trouble
A 2 2	Cooling water pump overload
A 2 3	Crankshaft angle sensor trouble
A 2 4	Camshaft angle sensor trouble
A 2 5	Clutch trouble (handled as warning)
A 2 6	Misfire
A 2 7	Catalyst temp. trouble
A 2 8	Generator trouble
A 2 9	Converter trouble
A 3 0	Fuel gas pressure low

System E (communications system trouble)

Outdoor unit control board display	Contents
E 0 1	Remote controller receiving failure
E 0 2	Remote controller sending failure
E 0 3	Indoor unit failed to receive signal from remote controller (central)
E 0 4	Indoor unit failed to receive signal from outdoor unit
E 0 5	Indoor unit failed to send signal to outdoor unit
E 0 6	Outdoor unit failed to receive signal from indoor unit
E 0 7	Outdoor unit failed to send signal to indoor unit
E 0 8	Duplicate indoor unit address
E 0 9	Multiple units set as master remote controller
E 1 0	Communications failure with DC fan driver
E 1 1	Indoor board failed to receive signal from signal output board

Outdoor unit control board display	Contents
E 1 2	Automatic address setting is in progress; automatic address setting start is prohibited
E 1 3	Indoor unit failed to send signal to remote controller
E 1 5	Automatic address setting warning (too few units)
E 1 6	Automatic address setting warning (too many units)
E 1 8	Group control cable communications failure
E 2 0	Automatic address indoor unit does not exist
E 2 1	PCB (Control Board) trouble
E 2 2	Thermistor trouble
E 2 4	Communications failure between outdoor units
E 2 6	Discrepancy in the number of outdoor units
E 3 1	Unit internal communications failure

System F (trouble with sensors, memory, or other parts)

Outdoor unit control board display	Contents
F 0 1	Indoor heat exchanger inlet temp. sensor trouble
F 0 2	Indoor heat exchanger intermediate temp. sensor trouble (Water heat exchanger freezing sensor trouble)
F 0 3	Indoor heat exchanger outlet temp. sensor trouble
F 0 4	Compressor outlet temp. sensor trouble
F 0 6	Outdoor heat exchanger inlet temp. sensor trouble
F 0 7	Outdoor heat exchanger outlet temp. sensor trouble
F 0 8	Outdoor temp. sensor trouble
F 1 0	Indoor unit intake air temp. sensor trouble
F 1 1	Indoor unit discharge air temp. sensor trouble
F 1 2	Compressor inlet temp. sensor trouble
F 1 3	Cooling water temp. sensor trouble

Outdoor unit control board display	Contents
F 1 6	Compressor inlet/outlet pressure sensor trouble
F 1 7	Optical sensor trouble
F 1 8	Exhaust gas temp. sensor trouble
F 2 0	Clutch coil temp. sensor trouble
F 2 1	Clutch coil 2 temp. sensor trouble
F 2 5	Coolant heat exchanger for heating inlet temperature sensor failure
F 2 6	Coolant heat exchanger for heating outlet temperature sensor failure
F 2 9	Indoor nonvolatile memory (EEPROM) trouble
F 3 0	Clock function (RTC) trouble
F 3 1	Outdoor nonvolatile memory (EEPROM) trouble

System L (settings trouble)

Outdoor unit control board display	Contents
L02	Mismatch of indoor/outdoor unit types (Non-GHP device present)
L03	Multiple master units set for group control
L04	Duplicate system address settings
L05	Duplicate indoor unit priority settings (priority indoor unit)
L06	Duplicate indoor unit priority settings (other than priority indoor unit)
L07	Group control cable present for individual-control indoor unit
L08	Indoor unit address not set

Outdoor unit control board display	Contents
L09	Indoor unit capacity not set
L10	Outdoor unit capacity not set
L13	Indoor unit type setting failure
L15	Indoor unit pairing trouble
L16	Water heat exchanger unit setting failure
L17	Mismatch in outdoor units
L19	Water heat exchanger unit parallel address duplication
L21	Gas type setting failure

System P (activation of indoor/outdoor protection devices)

Outdoor unit control board display	Contents
P01	Indoor unit fan trouble
P03	Compressor discharge temp. high
P04	Refrigerant high-pressure switch activated
P05	Power phases reversed (open phase)
P09	Indoor unit ceiling panel connector connection failure
P10	Indoor unit float switch trouble
P11	Indoor unit drain pump error Water heat exchanger unit freezing trouble
P12	Indoor unit DC fan trouble
P13	Refrigerant circuit failure

Outdoor unit control board display	Contents
P14	O ₂ sensor failure
P15	Refrigerant gas completely absent
P18	Bypass valve failure
P19	4-way valve lock trouble
P20	Refrigerant pressure too high
P22	Outdoor unit fan (inverter) trouble
P23	Water heat exchanger unit interlock trouble
P26	Clutch connection trouble
P31	Group control trouble

Other

Outdoor unit control board display	Contents
P30	Group slave unit trouble (trouble detected by system controller)
Oil	Oil change time warning ( appears on the Remote Controller)
DEF	Defrosting fault alarm
SO0.0E	High power backup operation
H07	Compressor oil empty
H08	Trouble with temp. sensor for oil level measurement

If the system does not operate normally after the above causes of trouble have been corrected, or if any display other than the above appears on the remote controller display, refer to the "TROUBLESHOOTING" in the separate <Technical Service Materials>.

During a remote controller test run, P09 is not detected.

Some of the displays may not appear depending on the model type.

16. Diagnostic Self-Check List (U-10MES2E8)

How to know LEDs 1 and 2 alarm display on outdoor unit control board

LED 1	LED 2	Contents of Alarm Display															
✱	✱	Alarm display															
Alternating		After LED1 blinks M times, LED2 blinks N times. This will be repeated. <table border="1" style="margin: 10px auto;"> <thead> <tr> <th></th> <th>Number of blinks</th> <th>Type of alarm</th> </tr> </thead> <tbody> <tr> <td rowspan="5" style="text-align: center; vertical-align: middle;">M</td> <td style="text-align: center;">2</td> <td style="text-align: center;">Alarm P</td> </tr> <tr> <td style="text-align: center;">3</td> <td style="text-align: center;">Alarm H</td> </tr> <tr> <td style="text-align: center;">4</td> <td style="text-align: center;">Alarm E</td> </tr> <tr> <td style="text-align: center;">5</td> <td style="text-align: center;">Alarm F</td> </tr> <tr> <td style="text-align: center;">6</td> <td style="text-align: center;">Alarm L</td> </tr> </tbody> </table>			Number of blinks	Type of alarm	M	2	Alarm P	3	Alarm H	4	Alarm E	5	Alarm F	6	Alarm L
	Number of blinks	Type of alarm															
M	2	Alarm P															
	3	Alarm H															
	4	Alarm E															
	5	Alarm F															
	6	Alarm L															
		N = number of alarm No.															
		For example: After LED1 blinks twice, LED2 blinks 17 times. This will be repeated. The alarm shows "P17".															

(✱ : Blink) Connect the outdoor unit maintenance remote controller to the RC plug (3P, BLU) on outdoor unit control board and make confirmation.

Table 8

Remote control display	Alarm contents
E06	Outdoor unit receiving failure from indoor unit
E12	Prohibit starting auto address setting
E15	Auto address alarm (A small number of indoor units)
E16	Auto address alarm (A large number of indoor units)
E20	No indoor unit during auto address setting
E21	Receiving failure of main system from sub system when link wiring is used for outdoor units
E22	Receiving failure of sub system from main system when link wiring is used for outdoor units
E24	Receiving failure of relay control unit from outdoor unit(s)
E25	Failure of outdoor unit address setting (Duplicative)
E26	Inconsistencies in number of outdoor units
E29	Failure of outdoor unit to receive relay control unit
E30	Failure of transferring outdoor unit serial
E31	Wiring error between the P.C. board ([L-Pow], [HIC] wire)
F04	Compressor 1 discharge temperature sensor abnormal [DISCH1]
F05	Compressor 2 discharge temperature sensor abnormal [DISCH2]
F06	Outdoor unit heat exchanger 1 gas (inlet) temperature sensor abnormal [EXG1]
F07	Outdoor unit heat exchanger 1 liquid (outlet) temperature sensor abnormal [EXL1]
F08	Outdoor temperature sensor abnormal [TO]
F12	Compressor inlet temperature sensor abnormal [SCT]
F14	Supercooling gas temperature sensor abnormal [SCG]
F16	High pressure sensor abnormal, high-load [HPS]
F17	Low pressure sensor abnormal [LPS]
F23	Outdoor unit heat exchanger 2 gas (inlet) temperature sensor abnormal [EXG2]
F24	Outdoor unit heat exchanger 2 liquid (outlet) temperature sensor abnormal [EXL2]
F31	Outdoor unit nonvolatile memory (EEPROM) error
H01	Compressor 1 abnormal current values (Overcurrent)
H03	Compressor 1 CT sensor disconnected, short-circuit
H05	Compressor 1 discharge temperature sensor disconnected
H06	Low pressure abnormal lowering
H07	Oil loss - error
H08	Oil sensor (connection) error 1

Remote control display	Alarm contents
H11	Compressor 2 abnormal current values (Overcurrent)
H13	Compressor 2 CT sensor disconnected, short-circuit
H15	Compressor 2 discharge temperature sensor disconnected
H21	Compressor 2 HIC alarm
H27	Oil sensor (connection) error 2
H31	Compressor 1 HIC alarm
L04	Outdoor unit address settings duplicated
L05	Indoor unit priority duplicated (For priority indoor)
L06	Indoor unit priority duplicated (Not for priority indoor) and outdoor unit
L10	Outdoor unit capacity settings not made
L17	Inconsistencies in outdoor unit models
L18	4-way valve coil disconnected, line disconnected
P03	Compressor 1 discharge temperature error
P04	Actuation of high pressure switch
P05	Compressor 1 open phase detection
P11	Cooling water freeze (chiller)
P14	Actuation of O ₂ sensor
P15	Compressor 2 open phase detection
P16	Compressor 1 secondary overcurrent
P17	Compressor 2 discharge temperature error
P19	Compressor 2 wiring open phase, start failure caused by DCCT failure (DC compressor start failure)
P20	High load (Forgot to open valves)
P22	Outdoor unit fan1 failure (IPM damage, overcurrent, inverter failure, DC fan lock, hole IC open phase)
P23	Inter lock not cancellation (chiller)
P24	Outdoor unit fan2 failure (IPM damage, overcurrent, inverter failure, DC fan lock, hole IC open phase)
P26	Compressor 2 secondary overcurrent
P29	Compressor 1 wiring open phase, start failure caused by DCCT failure (DC compressor start failure)

- Contents of alarm display on remote controller

For the remote controller, there are other alarm contents listed on the following table besides the alarm display on outdoor unit control board.

Table 9

Wired remote control display	Detected contents	
<E01>	Remote controller detects abnormal signal transmitted from the indoor unit.	<ul style="list-style-type: none"> • Failure of remote controller to receive. (For group control, signal from the main unit.) • No setting of system address, indoor unit address, indoor unit individualization / main / sub (Auto address setting not completed.)
<E02>		Remote controller not connected properly.
<<E03>>	Indoor unit failed to receive serial signal by remote controller (or central controller).	
E04	Indoor unit detects abnormal signal from outdoor main unit control P.C. board.	<ul style="list-style-type: none"> • Receiving failure of remote controller (For group control, signal from the main unit.) • Inconsistencies in number of connected units and setting units when outdoor unit is turned ON power. (Excepting the system address "0")
E08	Setting failure	Indoor unit address settings duplicated
<<E09>>		Main remote control settings duplicated
E18	Indoor unit communication error in group control wiring	Main indoor unit failed to receive serial signal from sub indoor unit.
<<L02>>	Setting failure	Indoor unit connected to multiple outdoor units is not for multiple type.
<L03>		Main unit settings duplicated in group control indoor units
L07		Group control wiring connected to individual control indoor unit
L08		Indoor unit address settings not made
<<L09>>		Indoor unit capacity settings not made

Wired remote control display	Detected contents	
<<F01>>	Indoor unit thermistor failure	Heat exchanger temperature sensor E1
<<F02>>		Water heat exchanger temperature sensor E2 (chiller)
<<F03>>		Heat exchanger temperature sensor E3
<<F10>>		Inlet temperature sensor
<<F11>>		Outlet temperature sensor
<<P09>>	Connection failure of ceiling panel or connector	
<<P01>>	Indoor unit protection	Fan protection thermostat
<<P10>>		Float switch
<<P12>>		Actuation of fan inverter protecting function
F29	Nonvolatile memory IC (EEPROM) failure on indoor unit control P.C. board	



- The parentheses of << >> used in the table of alarm display does not affect anything the operation of other indoor units.
- The parentheses of < > used in the table of alarm display implies that there are two cases : according to the content of the symptom, some affect the operation of other indoor units and others do not affect anything.

17. Checking the Indoor Unit Addresses

- This is done using the remote controller.
- If a remote controller is connected to each indoor unit, the address is displayed at the remote controller as the “unit number”.

If a remote controller is not connected to each indoor unit, follow the procedure below and use the remote controller to operate each indoor unit, one at a time, in fan mode to check the address of each.

<Checking addresses by operating units in fan mode>

- (1) Press the  button and the timer time  button simultaneously. (Press and hold for at least 4 seconds.) This switches the remote controller to address-change mode.
- (2) Select the outdoor unit refrigerant system (outdoor unit address).
Use the **UNIT** button and the **FLAP** button to select the refrigerant system, then press the **SET** button to confirm it.
(**UNIT** = UP button **FLAP** = DOWN button)
- (3) Check the indoor unit address.
When the **SET** button is pressed in step (2), the indoor unit corresponding to the address displayed (flashing) on the remote controller begins operating in fan mode.
Find and check the indoor unit that is operating.
- (4) Display of the address number
After checking the operation of the indoor unit, display the address number in a prominent position.
(This will be required later for maintenance.)
- (5) Select the address of the indoor unit with the **UNIT** button sequentially for the blast operation.
Conduct the operation of (4).
- (6) After checking the addresses of all indoor units, press the  button once return the remote controller to normal mode.

18. Changing the Indoor Unit Addresses (If Necessary)

- This is done using the remote controller.

● Changing the addresses

(1) Follow the step (1) and (2) in Section 17 in order to select an outdoor unit refrigerant system and press the **SET** button to confirm it.

(2) Select the indoor unit.

Use the **UNIT** button to select the indoor unit for the address change.

(3) Select the desired address.

Press the timer time and buttons to select the desired address.

(4) Press the **SET** button to confirm the address change.

(5) Repeat steps (2) through (4) to change addresses within the same refrigerant system.

(6) To make changes to the indoor unit addresses in the next refrigerant system:

Press the **↺** button to return to address-change mode.

Use the **UNIT** button and **FLAP** button to select the next refrigerant system, then repeat steps (2) through (4).

(7) When address changes are completed, press the **↺** button twice.

The remote controller returns to normal mode.

Note: Returning from the status in (3) to the status in (2) (cancel function)

From the status in (3), press the **CANCEL** button without pressing the **SET** button.

The change cannot be canceled after the **SET** button has been pressed.

Next, press the **↺** button to return from address-change mode to normal mode.

19. Precautions

- Request that the customer be present for the test run.
Explain the contents of the instruction manual, then have the customer actually operate the system.
- Be sure to give the instruction manual and warranty certificate to the customer.

20. TEST RUN U-10MES2E8

20-1. Preparing for Test Run

● Before attempting to start the air conditioner, check the following.

- (1) All loose matter is removed from the cabinet especially steel filings, bits of wire, and clips.
- (2) The control wiring is correctly connected and all electrical connections are tight.
- (3) The protective spacers for the compressor used for transportation have been removed. If not, remove them now.
- (4) The transportation pads for the indoor fan have been removed. If not, remove them now.
- (5) The power has been connected to the unit for at least 5 hours before starting the compressor. The bottom of the compressor should be warm to the touch and the crankcase heater around the feet of the compressor should be hot to the touch.

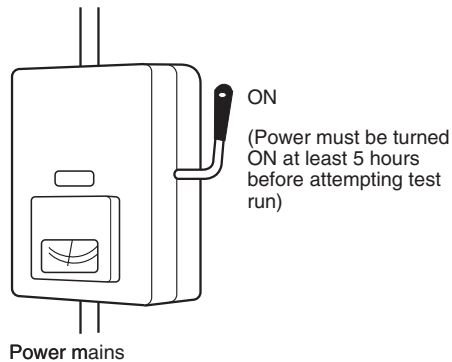

- (6) Both the gas and liquid tube service valves are open. If not, open them now.

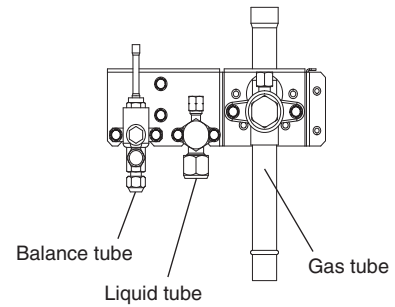

- (7) Request that the customer be present for the trial run. Explain the contents of the operating instructions, then have the customer actually operate the system.
- (8) Be sure to give the operating instructions and warranty certificate to the customer.
- (9) When replacing the control PCB, be sure to make all the same settings on the new PCB as were in use before replacement. The existing EEPROM is not changed, and is connected to the new control PCB.

20-2. Main Outdoor Unit PCB Setting

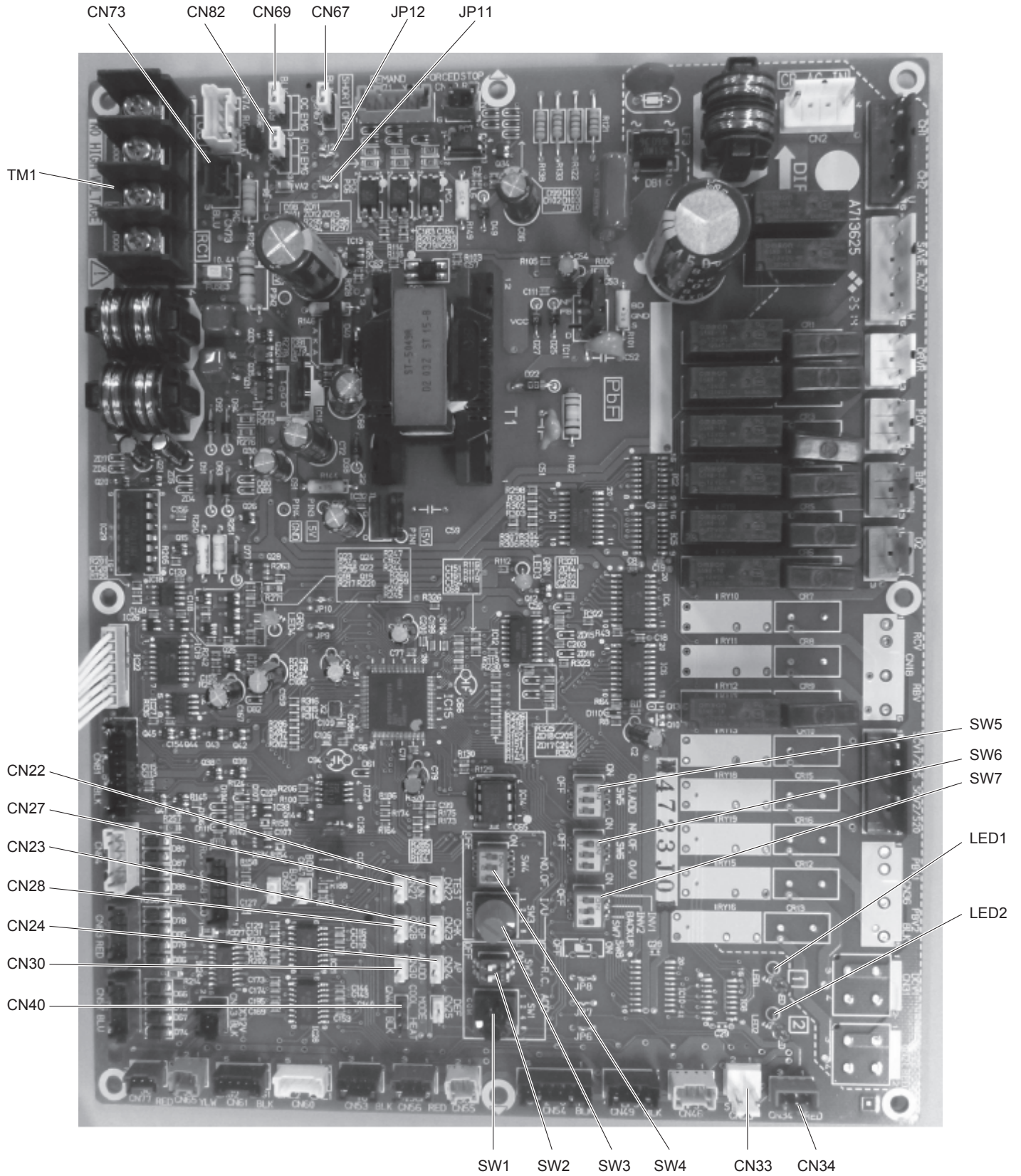

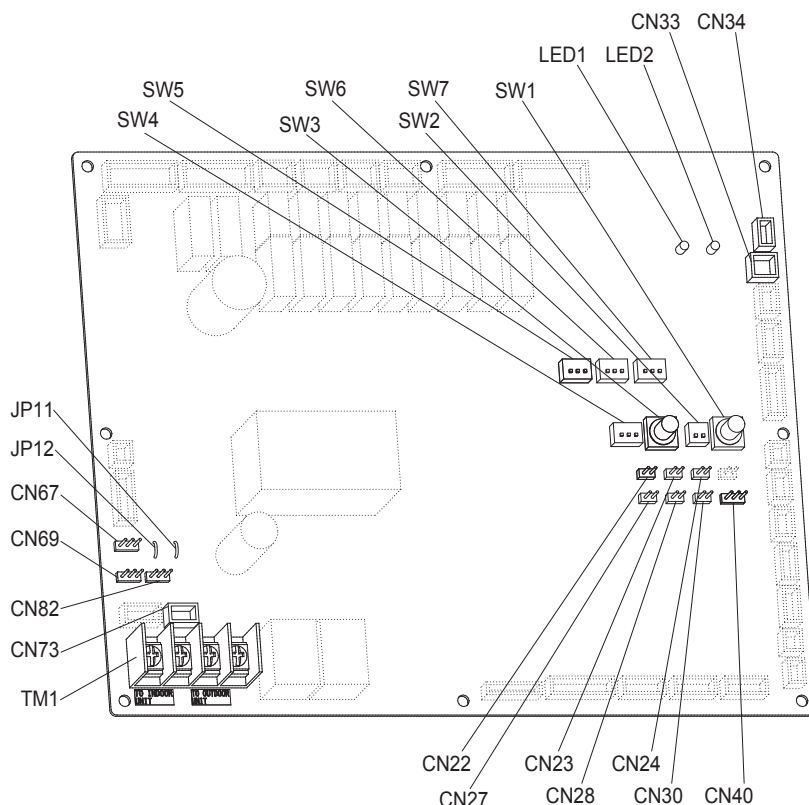

● Name And Function Of Each Switch On Outdoor Unit Control P.C. Board

Function Switch	Remarks
MODE pin (3P, BLK) (CN40)	Changes to cooling/heating mode. (outdoor main unit is only usable.) When in normal operation: When short circuited the COOL side, indoor unit operation in the same refrigerant system changes to all cooling mode. When short circuited the HEAT side, indoor unit operation in the same refrigerant system changes to all heating mode. When in auto address setting: Changes to heating mode with open-circuit.
A.ADD pin (2P, WHT) (CN30)	Short circuited for over 1 second long → Auto address setting starts with open-circuit. If short circuit lasts for over 1 second long during auto address setting, the setting is interrupted.
CHK pin (2P, WHT) (CN23)	When short circuited, test run begins. (If the remote controller is connected in test run mode, it is automatically cancelled after 1 hour.) Also, if short-circuit is cancelled, test run mode is cancelled.
RC plug (3P, BLU) (CN73)	Connects to outdoor unit maintenance remote controller and content of alarm message will be checked.
RUN pin (2P, WHT) (CN27)	When short circuited and pulse signal is given, all indoor units operate in the same refrigerant system.
STOP pin (2P, WHT) (CN28)	When short circuited and pulse signal is given, all indoor units stop in the same refrigerant system. (When short circuited, operation cannot be performed by the indoor unit's remote controller.)
AP pin (2P, WHT) (CN24)	Can be used when vacuuming the outdoor unit.
SNOW plug (3P, RED) (CN34)	Can be used when installing a snowfall sensor device.
SILENT plug (2P, WHT) (CN33)	Can be used when setting the outdoor unit fan in sound absorbing mode.
OC EMG terminal (3P, BLK) (CN69)	If "TO INDOOR UNIT" accidentally connected to high voltage, use the terminal base TM1. Method: 1. Replace the pins 1 and 2 of CN69 with the pins 2 and 3. 2. Disconnect JP1
RC1 EMG terminal (3P, BLK) (CN82)	If "TO OUTDOOR UNIT" accidentally connected to high voltage, use the terminal base TM1. Method: 1. Replace the pins 1 and 2 of CN82 with the pins 2 and 3. 2. Disconnect JP1

For details, refer to the Test Run Service Manual.

20-3. Auto Address Setting

Auto Address Setting from the High-spec Wired Remote Controller (CZ-RTC5A)

- Keep pressing the , and buttons simultaneously for 4 or more seconds.
The "Maintenance func" screen appears on the LCD display.
- Press the or button to see each menu.
If you wish to see the next screen instantly, press the or button.
Select "9. Auto address" on the LCD display and press the button.

Maintenance func	20:30 (THU)
9. Auto addr	
10. Set elec. consumpt	
11. Set touch	
12. Check touch	
◆ Sel. ◀ Page [◀] Confirm	

- The "Auto address" screen appears on the LCD display.
Change the "Code no." to "A1" by pressing the or button.

Auto address	20:30 (THU)
Code no.	O/D unit no.
▲ A1 ▼	1
◆ Sel. ▶ Next	

- Select the "O/D unit no." by pressing the or button.
Select one of the "O/D unit no." for auto address by pressing the or button.
Approximately about 10 minutes are required.
When auto address setting is completed, the units return to normal stopped status.

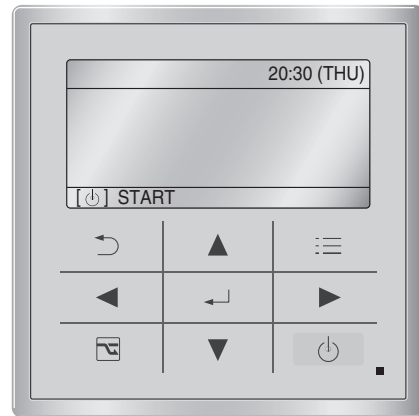

CZ-RTC5A

Auto Address Setting* from the Remote Controller (CZ-RTC4)

* Auto address setting in Cooling mode cannot be done from the remote controller.

NOTE

- Selecting each refrigerant system individually for auto address setting
- Auto address setting for each system
: Item code "A1"

- Press the remote controller timer time button and button at the same time.
(Press and hold for 4 seconds or longer.)
- Next, press either the temperature setting / button. (Check that the item code is "A1".)
- Use either the button to set the system No. to perform auto address setting.
- Then press the button.
(Auto address setting for one refrigerant system begins.) (When auto address setting for one system is completed, the system returns to normal stopped status.)
<Approximately 4 – 5 minutes is required.>
(During auto address setting, "SETTING" is displayed on the remote controller.
This message disappears when auto address setting is completed.)
- Repeat the same steps to perform auto address setting for each successive system.

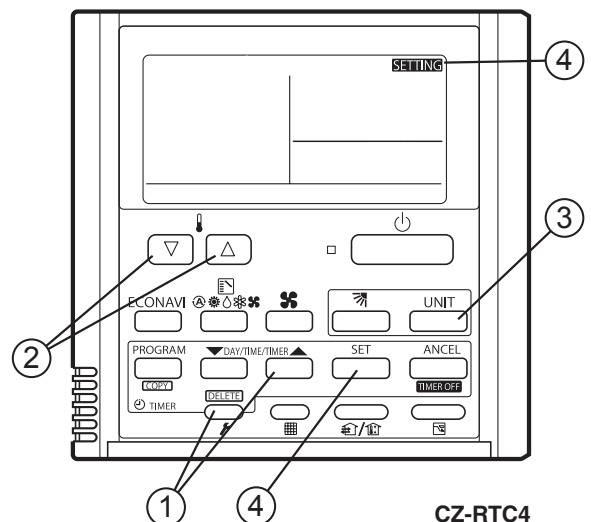

CZ-RTC4

Display During Auto Address Setting

- On the surface of outdoor unit control P.C. board

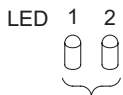

Blinks alternately

- * Do not short circuit the A.ADD pin (CN30) again during auto address setting. LEDs 1 and 2 go out and address setting is interrupted.
- * When auto address setting is normally completed, both LEDs 1 and 2 go out. In other cases, correct settings referring to the following table and perform auto address setting again.

- Contents of LEDs 1 and 2 on outdoor unit control P.C. board

☀ : Illuminating

⚡ : Blinking

● : Go out

LED 1	LED 2	Contents of display
☀	☀	After turned ON power (not during auto address setting), it is entirely impossible to communicate with the indoor unit in the system.
●	☀	After turned ON power (not during auto address setting), although the indoor units more than 1 unit in the system are recognized, there are inconsistencies between the number of indoor units and setting number of indoor units.
⚡	⚡	Under auto address setting
Alternately		
●	●	Auto address setting completed
⚡	⚡	There are inconsistencies between the number of indoor units and setting number of indoor units. (at the time of auto address setting)
Simultaneously		
⚡	⚡	See the section "7-6. Self-Diagnosis Function Table and Contents of Alarm Display".
Alternating		

- Display of remote controller

CZ-RTC5A

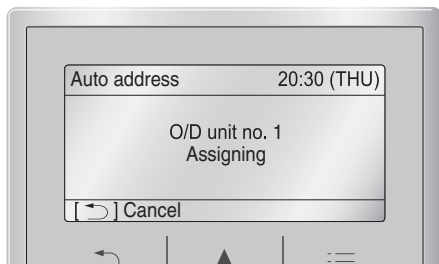

CZ-RTC4

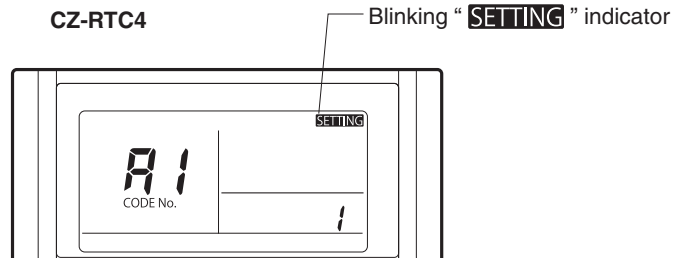

Request concerning recording the indoor/outdoor unit combination Nos.

After auto address setting has been completed, be sure to record them for future reference.

List the outdoor main unit system address and the addresses of the indoor units in that system in an easily visible location (next to the nameplate), using a permanent marking pen or similar means that cannot be abraded easily.



Example: (Outdoor) 1 - (Indoor) 1-1, 1-2, 1-3... (Outdoor) 2 - (Indoor) 2-1, 2-2, 2-3...

These numbers are necessary for later maintenance. Please be sure to indicate them.

Checking the indoor unit addresses



Use the remote controller to check the indoor unit address.

CZ-RTC5A (High-spec wired remote controller)

- Keep pressing the ,  and  buttons simultaneously for 4 or more seconds.
The "Maintenance func" screen appears on the LCD display.



Maintenance func 20:30 (THU)	
1. Outdoor unit error data	
2. Service contact	
3. RC setting mode	
4. Test run	
▼ Sel.	▶ Page [←] Confirm

- Press the  or  button to see each menu.

If you wish to see the next screen instantly, press the  or  button.

Select "7. Simple settings" on the LCD display and press the  button.

Maintenance func 20:30 (THU)	
5. Sensor info.	
6. Servicing check	
7. Simple settings	
8. Detailed settings	
↕ Sel.	◀ ▶ Page [←] Confirm

- The "Simple settings" screen appears on the LCD display.
Select the "Unit no." by pressing the  or  button for changes.

Simple settings 20:30 (THU)		
Unit no.	Code no.	Set data
3-1	01	0001
↕ Sel.	▶ Next	

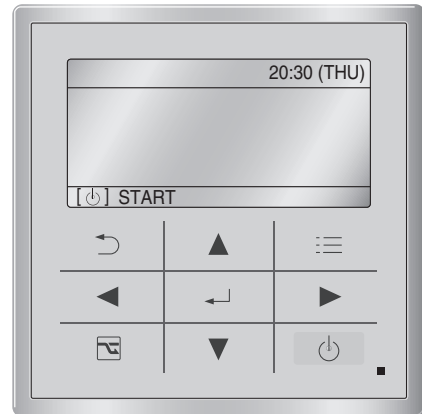

The indoor unit fan operates only at the selected indoor unit.



CZ-RTC5A

CZ-RTC4 (Timer remote controller)

<If 1 indoor unit is connected to 1 remote controller>





- Press and hold the  button and  button for 4 seconds or longer (simple settings mode).
- The address is displayed for the indoor unit that is connected to the remote controller.
(Only the address of the indoor unit that is connected to the remote controller can be checked.)
- Press the  button again to return to normal remote controller mode.

01		SETTING
CODE No.	SET DATA	XXXX
	UNIT No.	1-1

Number changes to indicate which indoor unit is currently selected.

Indoor unit address

<If multiple indoor units are connected to 1 remote controller (group control)>

- Press and hold the  button and  button for 4 seconds or longer (simple settings mode).
- "ALL" is displayed on the remote controller.
- Next, press the  button.
- The address is displayed for 1 of the indoor units which is connected to the remote controller. Check that the fan of that indoor unit starts and that air is discharged.
- Press the  button again and check the address of each indoor unit in sequence.
- Press the  button again to return to normal remote controller mode.



01		SETTING
CODE No.	SET DATA	XXXX
	UNIT No.	ALL

Number changes to indicate which indoor unit is currently selected.





Indoor unit address

20-4. Setting Test Run Remote Controller

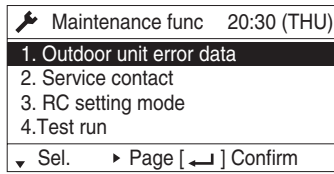
CZ-RTC5A (High-spec wired remote controller)



- ① Keep pressing the ,  and  buttons simultaneously for 4 or more seconds.
The "Maintenance func" screen appears on the LCD display.

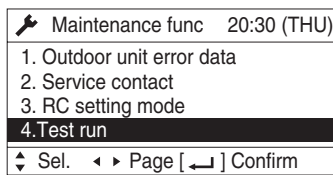

- ② Press the  or  button to see each menu.
If you wish to see the next screen instantly, press the  or  button.

Select "4. Test run" on the LCD display and press the  button.



Change the display from OFF to ON by pressing the  or  button. Then press the  button.

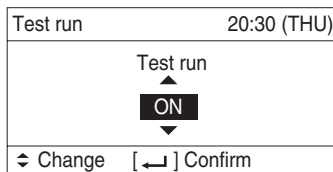

CZ-RTC4 (Timer remote controller)

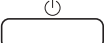
1. Press the remote controller  button for 4 seconds or longer.
Then press the  button.

- "TEST" appears on the LCD display while the test run is in progress.
 - The temperature cannot be adjusted when in Test Run mode. (This mode places a heavy load on the machines. Therefore use it only when performing the test run.)
2. The test run can be performed using the HEAT, COOL, or FAN operation modes.

NOTE

The outdoor units will not operate for approximately 3 minutes after the power is turned ON and after operation is stopped.

3. If correct operation is not possible, a code is displayed on the remote controller LCD display.
(See the section "7-6. Self-Diagnostic Function Table and Contents of Alarm Display" and correct the problem.)
4. After the test run is completed, press the  button again.
Check that "TEST" disappears from the LCD display.
(To prevent continuous test runs, this remote controller includes a timer function that cancels the test run after 60 minutes.)

* If the test run is performed using the wired remote controller, operation is possible even if the cassette-type ceiling panel has not been installed. ("P09" display does not occur.)

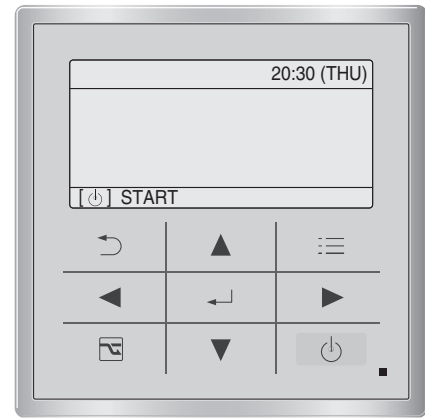

CZ-RTC5A

- ③ Press the  button. "TEST" will be displayed on the LCD display.

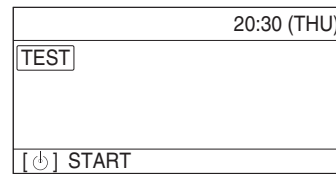

- ④ Press the  button. Test run will be started.
Test run setting mode screen appears on the LCD display.

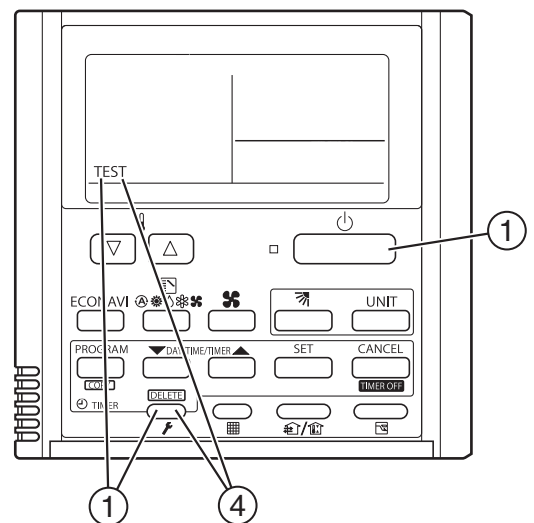
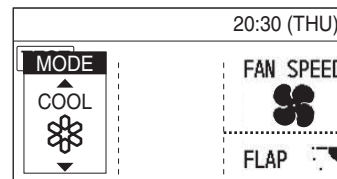

CZ-RTC4

20-5. Caution for Pump Down

Pump down means refrigerant gas in the system is returned to the outdoor unit.

Pump down is used when the unit is to be moved, or before servicing the refrigerant circuit.

(Refer to the Service Manual)



CAUTION

- This outdoor unit cannot collect more than the rated refrigerant amount as shown by the nameplate on the back.
- If the amount of refrigerant is more than that recommended, do not conduct pump down. In this case use another refrigerant collecting system.

7-6. Self-Diagnosis Function Table and Contents of Alarm Display

How to know LEDs 1 and 2 alarm display on outdoor unit control P.C. board

LED 1	LED 2	Contents of Alarm Display															
✱	✱	Alarm display															
Alternating		After LED1 blinks M times, LED2 blinks N times. This will be repeated.															
		<table border="1"> <thead> <tr> <th></th> <th>Number of blinks</th> <th>Type of alarm</th> </tr> </thead> <tbody> <tr> <td rowspan="5" style="text-align: center;">M</td> <td style="text-align: center;">2</td> <td style="text-align: center;">Alarm P</td> </tr> <tr> <td style="text-align: center;">3</td> <td style="text-align: center;">Alarm H</td> </tr> <tr> <td style="text-align: center;">4</td> <td style="text-align: center;">Alarm E</td> </tr> <tr> <td style="text-align: center;">5</td> <td style="text-align: center;">Alarm F</td> </tr> <tr> <td style="text-align: center;">6</td> <td style="text-align: center;">Alarm L</td> </tr> </tbody> </table>		Number of blinks	Type of alarm	M	2	Alarm P	3	Alarm H	4	Alarm E	5	Alarm F	6	Alarm L	N = number of alarm No.
	Number of blinks	Type of alarm															
M	2	Alarm P															
	3	Alarm H															
	4	Alarm E															
	5	Alarm F															
	6	Alarm L															
		For example: After LED1 blinks twice, LED2 blinks 17 times. This will be repeated. The alarm shows "P17".															

(✱ : Blink) Connect the outdoor unit maintenance remote controller to the RC plug (3P, BLU) on outdoor main unit control P.C. board and make confirmation.

■ Self-Diagnosis Function Table

- Cause and countermeasure against the symptom of auto address failure

Symptom	Cause and countermeasure
<ul style="list-style-type: none"> ● When turning ON power to the outdoor main unit, LEDs 1 and 2 illuminate or blink excluding going out. Auto address setting is not available. 	See "Contents of Alarm Display" and make corrections.
<ul style="list-style-type: none"> ● When auto address setting by the remote controller begins, the alarm display appears immediately. 	
<ul style="list-style-type: none"> ● When auto address setting by the remote controller begins, no display appears. 	Are remote control wiring and inter-unit control wiring connected properly? Is indoor unit turned ON power?

- Auto address setting begins but finishes improperly.

Symptom	Cause and countermeasure
<ul style="list-style-type: none"> ● Soon after a few seconds or after a few minutes, the alarm content is displayed on the remote controller. 	See "Contents of Alarm Display" and make a correction.
<ul style="list-style-type: none"> ● After a few minutes when auto address setting begins, the compressor may occasionally start and stop several times. LEDs 1 and 2 on outdoor unit control P.C. board show the display of auto address setting with blinking alternately but LEDs 1 and 2 do not indicate the completion of auto address setting (go out). 	Are remote control wiring and inter-unit control wiring connected properly? Is indoor unit turned ON power?

- If the alarm display “E15”, “E16” and “E20” appear after auto address setting began, check the following items.

Alarm display	Alarm contents
E15	Recognized number of indoor units at the time of auto address setting are fewer than that of indoor units set by SW3 and SW4 on outdoor main unit P.C. board.
E16	Recognized number of indoor units at the time of auto address setting are more than that of indoor units set by SW3 and SW4 on outdoor main unit P.C. board.
E20	Outdoor unit could not entirely receive serial communication signal from the indoor unit within 90 seconds after auto address setting began.

Check	E15	E16	E20
Have you forgotten to turn ON power to indoor unit?	<input type="radio"/>		<input type="radio"/>
Are indoor and outdoor control wiring connected properly? (Check for incorrect wiring to open & short-circuit, terminal pin and remote control terminal.)	<input type="radio"/>	<input type="radio"/>	<input type="radio"/>
Is remote control wiring connected properly? (Check for open & short-circuit, wrong connection to indoor/outdoor unit control wiring terminal, inter-unit control wiring.)	<input type="radio"/>		<input type="radio"/>
Are the number of the connecting indoor units set by SW3 and SW4 of outdoor main unit control P.C. board connected properly?	<input type="radio"/>	<input type="radio"/>	
Is additional appropriate amount of refrigerant charge? (Compressor ON at the time of auto address setting)	<input type="radio"/>		
Is the refrigerant tubing connected properly? (Compressor ON at the time of auto address setting)	<input type="radio"/>	<input type="radio"/>	
Are E1 and E3 sensors of indoor unit normal? (Compressor ON at the time of auto address setting)	<input type="radio"/>		
Are there any wrong system address installed in indoor units caused by manual or incorrect auto address control?		<input type="radio"/>	

- 1) When auto address setting from outdoor main unit control P.C. board or remote controller begins, “Under Setting” appears on the remote controller as for normal indoor units under the inter-unit control wirings and remote control wirings. LEDs 1 and 2 indicators on outdoor main unit control P.C. board blink alternately.
 - 2) If there is an error at the inter-unit control wiring of the remote controller when in the indoor unit group control, address setting may not occasionally be made although “under setting” is displayed.
 - 3) Although the alarm “E15” and “E16” are displayed, addresses will be installed in the recognized indoor units. The installed addresses can be checked by the remote controller. See the section “Checking the indoor unit address”.
- When operating the remote controller after auto address setting completed (LEDs 1 and 2 indicators on outdoor main unit control P.C. board go out), correct the symptom if the following alarms appear on the remote controller.

Remote control display	Cause
No display	Remote controller is not connected properly. (Power failure) When auto address setting was completed, the power of indoor unit was turned off.
E01	Remote controller is not connected properly. (Receiving failure from remote control) Indoor unit address was mistakenly controlled by undesired indoor unit remote controller. (Impossible to communicate with outdoor unit)
E02	Remote controller is not connected properly. (Impossible to communicate with indoor unit by remote controller)
P09	Connector of indoor unit ceiling panel is not connected properly.

If any other alarm appear on the display, refer to the Test Run Service Manual.

- Alarm display can be checked by the outdoor maintenance remote controller. When operating, refer to the Test Run Service Manual. Alarm display can also be checked by number of blinking of LEDs 1 and 2 on outdoor unit control P.C. board. (See the section “How to know LEDs 1 and 2 alarm display on outdoor unit control P.C. board” under the section “7-6. Self-Diagnosis Function Table and Contents of Alarm Display”.

Remote control display	Alarm contents
E06	Outdoor unit receiving failure from indoor unit
E12	Prohibit starting auto address setting
E15	Auto address alarm (A small number of indoor units)
E16	Auto address alarm (A large number of indoor units)

Remote control display	Alarm contents
E20	No indoor unit during auto address setting
E21	Receiving failure of main system from sub system when link wiring is used for outdoor units
E22	Receiving failure of sub system from main system when link wiring is used for outdoor units
E24	Receiving failure of relay control unit from outdoor unit(s)
E25	Failure of outdoor unit address setting (Duplicative)
E26	Inconsistencies in number of outdoor units
E29	Failure of outdoor unit to receive relay control unit
E30	Failure of transferring outdoor unit serial
E31	Wiring error between the P.C. board ([L-Pow], [HIC] wire)
F04	Compressor 1 discharge temperature sensor abnormal [DISCH1]
F05	Compressor 2 discharge temperature sensor abnormal [DISCH2]
F06	Outdoor unit heat exchanger 1 gas (inlet) temperature sensor abnormal [EXG1]
F07	Outdoor unit heat exchanger 1 liquid (outlet) temperature sensor abnormal [EXL1]
F08	Outdoor temperature sensor abnormal [TO]
F12	Compressor inlet temperature sensor abnormal [SCT]
F14	Supercooling gas temperature sensor abnormal [SCG]
F16	High pressure sensor abnormal, high-load [HPS]
F17	Low pressure sensor abnormal [LPS]
F23	Outdoor unit heat exchanger 2 gas (inlet) temperature sensor abnormal [EXG2]
F24	Outdoor unit heat exchanger 2 liquid (outlet) temperature sensor abnormal [EXL2]
F31	Outdoor unit nonvolatile memory (EEPROM) error
H01	Compressor 1 abnormal current values (Overcurrent)
H03	Compressor 1 CT sensor disconnected, short-circuit
H05	Compressor 1 discharge temperature sensor disconnected
H06	Low pressure abnormal lowering
H07	Oil loss - error
H08	Oil sensor (connection) error 1
H11	Compressor 2 abnormal current values (Overcurrent)
H13	Compressor 2 CT sensor disconnected, short-circuit
H15	Compressor 2 discharge temperature sensor disconnected
H21	Compressor 2 HIC alarm
H27	Oil sensor (connection) error 2
H31	Compressor 1 HIC alarm
L04	Outdoor unit address settings duplicated
L05	Indoor unit priority duplicated (For priority indoor)
L06	Indoor unit priority duplicated (Not for priority indoor) and outdoor unit
L10	Outdoor unit capacity settings not made
L17	Inconsistencies in outdoor unit models
L18	4-way valve coil disconnected, line disconnected
P03	Compressor 1 discharge temperature error
P04	Actuation of high pressure switch
P05	Compressor 1 open phase detection
P11	Cooling water freeze (chiller)
P14	Actuation of O ₂ sensor
P15	Compressor 2 open phase detection
P16	Compressor 1 secondary overcurrent
P17	Compressor 2 discharge temperature error
P19	Compressor 2 wiring open phase, start failure caused by DCCT failure (DC compressor start failure)
P20	High load (Forgot to open valves)
P22	Outdoor unit fan1 failure (IPM damage, overcurrent, inverter failure, DC fan lock, hole IC open phase)
P23	Inter lock not cancellation (chiller)
P24	Outdoor unit fan2 failure (IPM damage, overcurrent, inverter failure, DC fan lock, hole IC open phase)
P26	Compressor 2 secondary overcurrent
P29	Compressor 1 wiring open phase, start failure caused by DCCT failure (DC compressor start failure)

- Contents of alarm display on remote controller

For the remote controller, there are other alarm contents listed on the following table besides the alarm display on outdoor main unit control P.C. board.

Wired remote control display	Detected contents	
<E01>	Remote controller detects abnormal signal transmitted from the indoor unit.	<ul style="list-style-type: none"> ● Failure of remote controller to receive. (For group control, signal from the main unit.) ● No setting of system address, indoor unit address, indoor unit individualization / main / sub (Auto address setting not completed.)
<E02>		Remote controller not connected properly.
<<E03>>	Indoor unit failed to receive serial signal by remote controller (or central controller).	
E04	Indoor unit detects abnormal signal from outdoor main unit control P.C. board.	<ul style="list-style-type: none"> ● Receiving failure of remote controller (For group control, signal from the main unit.) ● Inconsistencies in number of connected units and setting units when outdoor unit is turned ON power. (Excepting the system address "0")
E08	Setting failure	Indoor unit address settings duplicated
<<E09>>		Main remote control settings duplicated
E18	Indoor unit communication error in group control wiring	Main indoor unit failed to receive serial signal from sub indoor unit.
<<L02>>	Setting failure	Indoor unit connected to multiple outdoor units is not for multiple type.
<L03>		Main unit settings duplicated in group control indoor units
L07		Group control wiring connected to individual control indoor unit
L08		Indoor unit address settings not made
<<L09>>		Indoor unit capacity settings not made
<<F01>>		Indoor unit thermistor failure
<<F02>>	Water heat exchanger temperature sensor E2 (chiller)	
<<F03>>	Heat exchanger temperature sensor E3	
<<F10>>	Inlet temperature sensor	
<<F11>>	Outlet temperature sensor	
<<P09>>	Connection failure of ceiling panel or connector	
<<P01>>	Indoor unit protection	Fan protection thermostat
<<P10>>		Float switch
<<P12>>		Actuation of fan inverter protecting function
F29		Nonvolatile memory IC (EEPROM) failure on indoor unit control P.C. board

- The parentheses of << >> used in the table of alarm display does not affect anything the operation of other indoor units.
- The parentheses of < > used in the table of alarm display implies that there are two cases : according to the content of the symptom, some affect the operation of other indoor units and others do not affect anything.

Alarm messages displayed on system controller			
Serial communication errors Mis-setting	Error in transmitting serial communication signal	Indoor or main outdoor unit is not operating correctly. Mis-wiring of control wiring between indoor unit, main outdoor unit and system controller.	C05
	Error in receiving serial communication signal	Indoor or main outdoor unit is not operating correctly. Mis-wiring of control wiring between indoor unit, main outdoor unit and system controller. CN1 is not connected properly.	C06
Activation of protective device	Protective device of sub indoor unit in group control is activated.	When using wireless remote controller or system controller, in order to check the alarm message in detail, connect wired remote controller to indoor unit temporarily.	P30

NOTE

1. Alarm messages in << >> do not affect other indoor unit operations.
2. Alarm messages in < > sometimes affect other indoor unit operations depending on the fault.

III. Checking the function and performance

1. Checking the function

(1) Changing the function setting

- If there is an indoor unit with a gas tube valve kit connected within the system, the function setting of that indoor unit can be changed from the outdoor main board of the outdoor unit connected to the indoor unit.
- Changing the setting is carried out after completing the address setting.

- ① Press the HOME (SW004) key for longer than 1 second, to display the menu item number. “ 0 0 0 0 ”
- ② Next, press the UP (SW005) or DOWN (SW006) key to display the menu item number. Select “ 0 0 0 0 ”
- ③ After displaying “ 0 0 0 0 ”, the indoor unit setting “ 5 E 1 0 ” is displayed. While the indoor unit setting is displayed, press the SET (SW007) key. The display changes as shown in the Figure 1. (Green LED lights up)

* In the case of Figure 18, the indoor unit is 1 and the data code is 1.

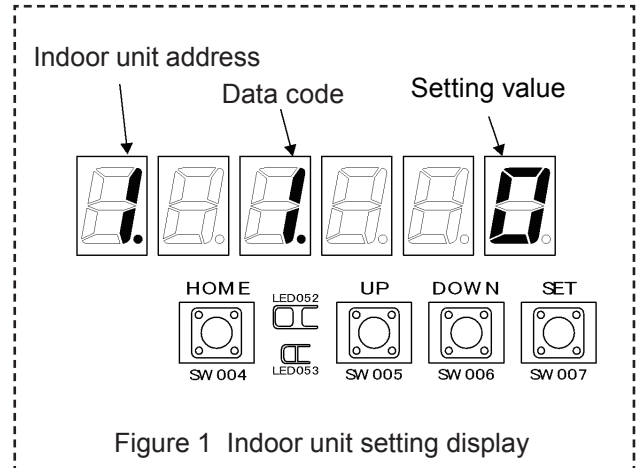

In this condition by using the UP (SW005) or DOWN (SW006) key, it is possible to select a setting item.

	Data code	Data name	Initial value	Remarks
↑ DOWN	1	Presence of gas tube valve	0	0 = N, 1 = Y
	2	Priority level	0	0 = Lowest priority 1= 1...4= Highest priority
	3	Drain pump intermittent control	0	0=None 1=4-way valve intermittent on the cooling side
	4	Drain pump continuous control	0	0=None 1=4-way valve continuous on cooling side
UP →	8	Humidifier setting	0	0=None 1=Heating dew condensation prevention control available
	L	Cooling blower temperature setting	0	0=By model -35=-35...92=92
	N	Heating blower temperature setting	0	0=By model -35=-35...92=92

- ④ While the status is indoor unit setting item selection, press the SET (SW007) key for longer than 1 second. The TEST/WARNING indicator (red LED (LED052)) lights up. In this condition, the DOWN (SW006) and UP (SW005) keys can be used to change the selected setting item.

* Changing the setting of the gas tube valve kit.
Select data code “1” (Presence of gas tube valve), and select the setting value “1” (Y). (Figure 2)

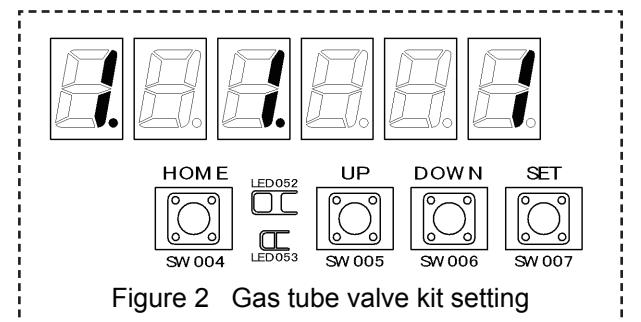

- ⑤ If you want to save the changed value to non-volatile memory, press the SET (SW007) key for longer than 1 second. The TEST/WARNING indicator (red LED (LED052)) turns off, and the status returns to indoor unit setting item selection. If you want to discard the changed value, press the HOME (SW004) key for longer than 1 second while the red LED (LED052) for indicating a test or warning is lit. (If the HOME (SW004) key is pressed for longer than 1 second during indoor unit setting item selection, the set content is not discarded.)

(2) Checking the function of the outdoor unit

① Checks before starting the engine (* Carry out these checks for all outdoor units of the corresponding refrigerant system.)

❶ Has the crankcase heater been energized for 5 hours before starting the test run?

❷ Is the bottom part of the compressor warmed up?

* If the above conditions have not been fulfilled there is a danger of damage to the compressor, and great inconvenience being caused to the customer. Under no circumstances should you start operating until these conditions are fulfilled.

② Setting the test run mode (only possible when all the indoor units are turned off)

* If a test run is set from the outdoor main board of the smallest address unit, a test run starts for all outdoor units connected to the same refrigerant tubing system.

* The test run can be canceled from the outdoor main board of the smallest address unit.

Even if trouble occurs between the indoor unit and remote controller (communication failure), a test run can be carried out from the outdoor unit. Therefore, after carrying out the test run with the outdoor unit, be sure to test run with the remote controller.

❶ Turn all the remote controller switches to “OFF”.

❷ Press the HOME (SW004) key for longer than 1 second to display the menu item number “ 0 0 0 0 ”.

❸ Next, press the UP (SW007) and DOWN (SW006) keys to select the menu item number “ 0 0 0 4 ”.

❹ After displaying “ 0 0 0 4 ”, display the test run/forced setting display “ E E E E ”.

❺ While the status is test run/forced setting display, press the SET (SW007) key to display the indication shown in the figure below. In this condition, use the UP (SW005) or DOWN (SW006) key to select the forced cooling test run setting mode or the forced heating test run setting mode.

❻ While the forced test run setting mode is selected (figure below), press the SET (SW005) key for longer than 1 second to perform the cooling (heating) test run. The TEST/WARNING indicator (red LED (LED052)) is lit during this time.

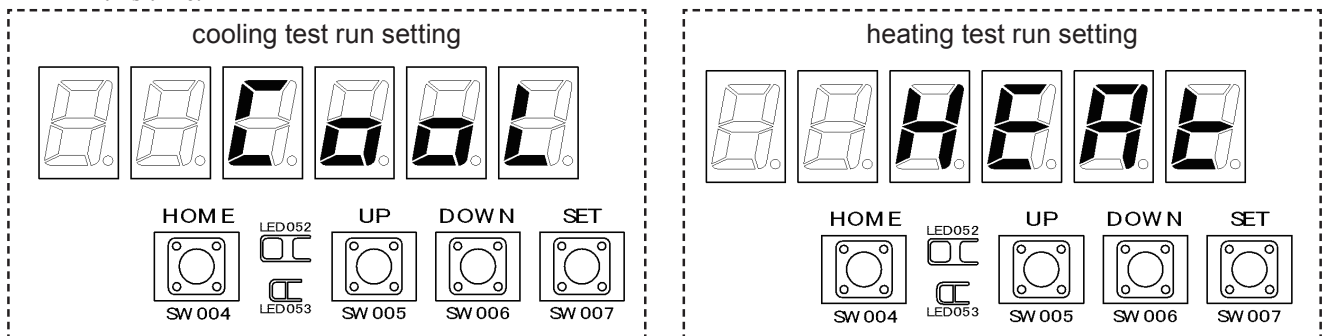

③ Checking the engine function (* Carry out these checks for all outdoor units of the corresponding refrigerant system.)

❶ Checking the starting performance

- After completely removing air from the gas tubing, start the engine with the first crank.
- During starting, overshoot or undershoot does not cause the protection device to work. After starting when the vane of the compressor is out or when the clutch is on there is a temporary reduction in the rotation speed. This is not a problem however.

❷ Rotation speed display mode setting

a) During normal operation, at 10 second intervals the “system address, number of indoor units” and “engine operating hours” are displayed alternately.

b) In this condition, press the SET (SW007) key to display the system data. (Figure 3).

c) While data is displayed, each press of the UP (SW005) key changes the display of the data code and data in order. Set the data code to “ 3 ” (Figure 4)

* If the HOME (SW004) key is pressed or no operation is performed for 10 minutes, the normal display is restored.

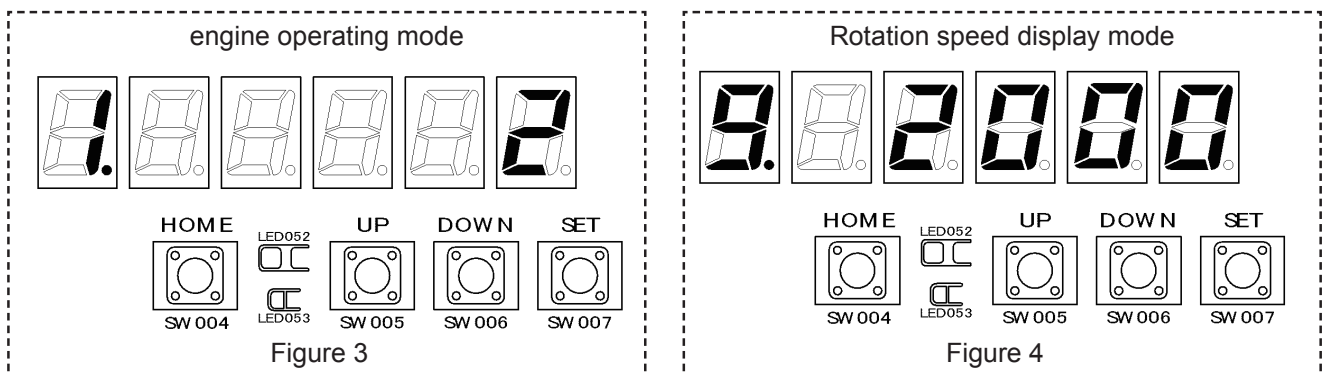

③ Checking the rotation speed.

There should be no hunting (variations in the rotation speed should be within 60min^{-1}).

* However, the set revolution speed varies depending on the air conditioning load, so perform this check after about 15 minutes has elapsed since the test run has been set and when operation has stabilized.

④ Checking for error noise or vibrations (* Carry out these checks for all outdoor units of the corresponding refrigerant system.)

① Change the number of indoor units from the minimum to the maximum, and at each number of indoor units check for the presence of error noises.

a) Press the HOME (SW004) key for longer than 1 second, to display the menu item number. “ 0 0 0 0 . ”

b) Press the UP (SW005) or DOWN (SW006) key to select the menu item number “ 0 0 0 0 . ”

c) After “ 0 0 0 0 . ” is displayed the status of indoor units connected is displayed (Figure 5).

d) Then press the SET (SW007) key to display the indoor unit thermostat. (Figure 6)

*The vertical bars from the upper left to upper right are indoor units 1 to 12 and the vertical bars from the lower left to lower right are indoor units 13 to 24. The top horizontal bars from left to right are indoor units 25 to 30 and the bottom horizontal bars from left to right are indoor units 31 and 32. (Figure 7) In this state, the display screen for units 1–32 and display screen for units 33–64 can be switched by pressing the UP (SW005) or DOWN (SW006) key. The vertical bars from the upper left to upper right are indoor units 33 to 44 and the vertical bars from lower left to lower right are indoor units 45 to 56. The top horizontal bars from left to right are indoor units 57 to 62 and the bottom horizontal bars from left to right are indoor units 63 and 64. (Figure 7)

Note: The display screen for units 1–32 has one dot in

the bottom right and the display screen for units 33–64 has two dots in the bottom right. (Refer to Figure 7)

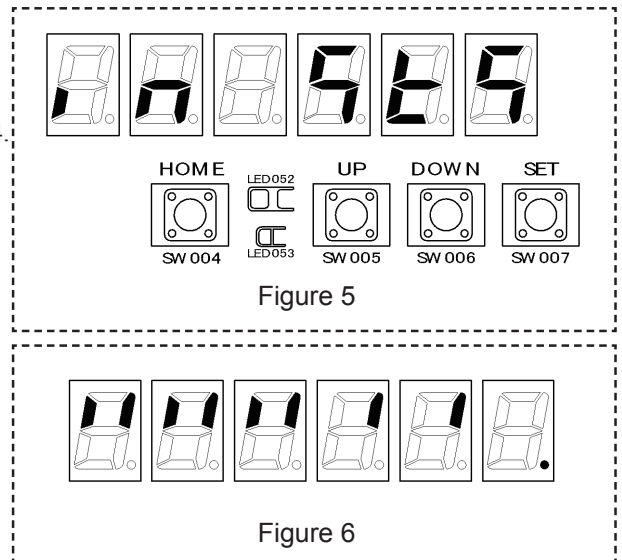

* A light turns on to indicate that the thermostat of the corresponding indoor unit is ON, blinks at 1-second intervals to indicate the thermostat of the corresponding indoor unit is OFF, and blinks at 0.5-second intervals to indicate the forced thermostat OFF setting is set for the corresponding indoor unit.

- e) While the indoor unit thermostats are displayed, press the SET (SW007) key. The display changes to indoor unit forced thermostat OFF setting. Select the indoor units that are to be forced OFF. (* Set this setting from the smallest address unit of the corresponding refrigerant system.)
- * A light turns on to indicate that the thermostat of the corresponding indoor unit is ON, blinks at 1-second intervals to indicate the thermostat of the corresponding indoor unit is OFF, blinks at 0.5-second intervals to indicate the forced thermostat OFF setting is set for the corresponding indoor unit, and blinks at high speed to indicate the number of the indoor unit being set.
 - * Use the UP (SW005) or DOWN (SW006) key to select the number of the indoor unit to be forced to stop. The screen automatically switches to display units 33–64 for numbers exceeding 32.

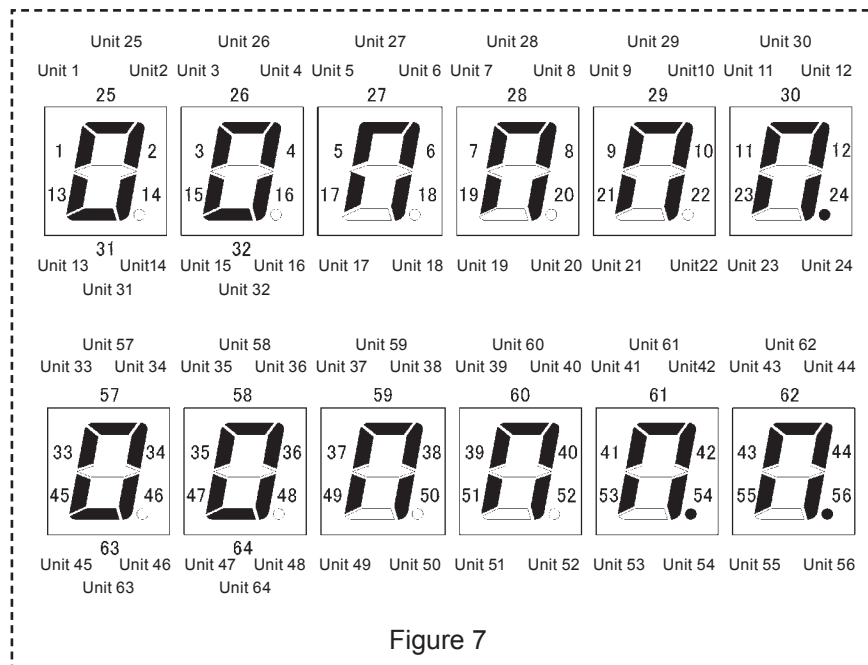

- f) After selecting the number of the indoor unit to be forced to stop, press the SET (SW007) key for longer than 1 second. The forced thermostat OFF setting is set for the selected indoor unit. TEST/WARNING indicator (red LED (LED052)) lights up.
- In order to cancel the forced stop, after selecting the number of the indoor unit, press the SET (SW007) key for longer than 1 second. The forced thermostat OFF setting is canceled for the selected indoor unit. TEST/WARNING indicator (red LED (LED052)) goes off.
- g) After completing the tests, remove the setting.

- Check that there is no error metallic noise from the compressor.
- Check that there is no error metallic noise or tappet noises from the engine.

② Check that there is no error vibration in each part of the units.

- Check that there is no error vibration in the refrigerant tubing or capillary tubes. (particularly during low rotational speeds)
 - Check that there are no error vibrations due to contact between tubing, fittings, panels, etc.
- a) For safety, when the outdoor units are stopped, set the total stop setting (Set SW001 (STOP-SW) to “STOP”) on all outdoor main boards of the corresponding refrigerant system.

(3) Checking the indoor units and remote controller

- Stop the outdoor unit test run and remove the forced thermostat OFF setting on the indoor units. (turn the Stop switch (STOP SW) to “NORM”)
- With each remote controller individually, check that the combination of indoor unit and remote controller unit number display label agree.

■ CZ-RTC4

Part Names Control panel

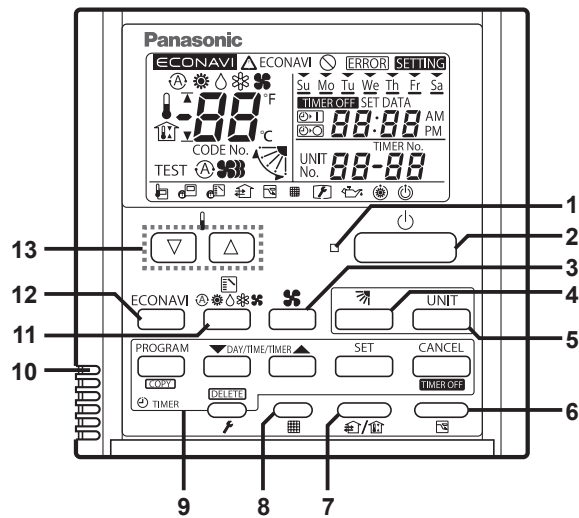

1 Operation indicator

Illuminates during operation. Blinks during alarm.

2 Start/Stop button

Starts/Stops operation.

3 Fan speed

Changing the fan speed.

4 Swing/Air direction

Use this button to set the auto swing or air direction to a specific angle.

5 Unit select

When more than one indoor unit is operated by one remote control unit, this button is used to select a unit when adjusting the air direction.

6 Sleeping

7 Ventilation

Use this button when you installed a fan available in the market. Pressing this button turns on and off the fan. When turning off the air conditioner, the fan will be also turned off.

8 Filter reset

Use this button to reset the filter sign. When is displayed, press this button after cleaning the filter.

9 Timer setting buttons

10 Remote control sensor

Normally, the temperature sensor of the indoor unit is used to detect the temperature. However, it is also possible to detect the temperature around the remote control unit.

11 Mode select

Pushing this button selects an operation mode.

12 ECONAVI

Use this button to turn on/off the ECONAVI Function.

13 Temperature setting buttons

Changing the temperature setting.

Screen display

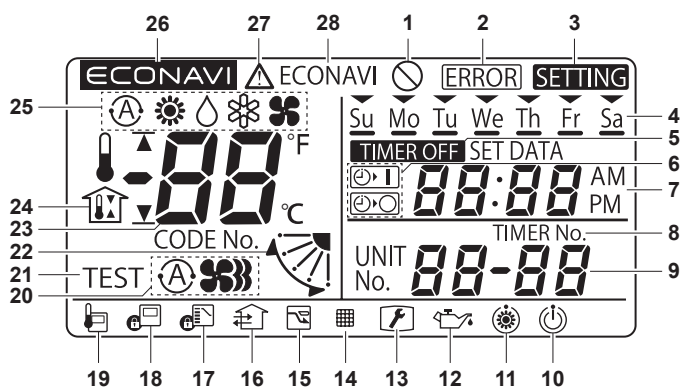

- 1 Displayed if the selected feature was disabled during installation.
- 2 Displayed when a mistake is made during timer setting.
- 3 Appears when the timer program is being set.
- 4 Indicates today's day of the week.
- 5 Displayed when the timer has been turned OFF.
- 6 Timer program indication
 - ☉|: The indoor unit starts operation at the programmed time.
 - ☉○: The indoor unit stops operation at the programmed time.
- 7 Displays the present time on a 24-hour clock. Also, displays settings in the various setting modes.
- 8 Appears when the time program is being set.
- 9 Indicates the unit No. of the selected indoor unit.
- 10 Appears during the peak cut mode (Demand) if an electric heat pump (EHP) air conditioner is used or during standby if a gas heat pump (GHP) air conditioner is used.
- 11 Appears when the fan of the indoor unit is stopped or in low fan speed.
- 12 The engine oil needs to be replaced. (Only when using a gas heat pump air conditioner.)
- 13 Appears when the maintenance function (monitoring sensor temperatures) is activated.
- 14 The indoor unit filter needs to be cleaned.
- 15 Appears during the sleeping function.
- 16 Appears when a fan available in the market is installed and is operating.
- 17 Switching operation modes is prohibited. (Switching to Auto mode is also prohibited.)
- 18 Remote control operation is restricted by a central control device.
- 19 Appears when the remote control sensor is used.
- 20 The selected fan mode is displayed.
- 21 Appears while in test operation.
- 22 Indicates the flap position.
- 23 Indicates the set temperature.
- 24 Appears during the outing function.
- 25 Displays the selected operation mode.
(AUTO (A)/HEAT ☀/DRY ☾/COOL ❄/FAN 🌀)
- 26 Appears when ECONAVI is being set to ON.
- 27 When inspection is required.
- 28 Appears with displaying 27 if there is a problem on ECONAVI.

Basic Operations

Setting the Present Time

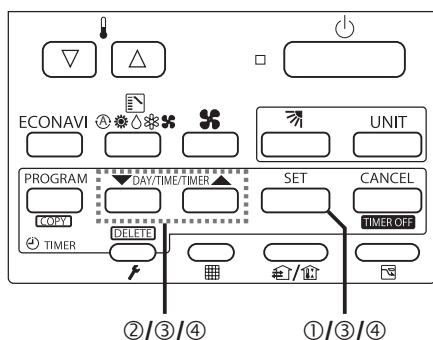

- ① Press and hold [SET] for more than 2 seconds to enter the present day and time setting mode. Once you enter the setting mode, “SETTING”, “▼”(day) and “time” fl ash.
- ② Set “▼” to today’s day of the week.
Press [▲] to move “▼” (fl ashing on the display) in the order of: Su → Mo → Tu →
Press [▼] to move it in the order of: Su → Sa → Fr →
Press [SET] to store.
- ③ Press [▼/▲] to change the present “hour” in the range of 0 to 23^{*1}.
Set the present hour and press [SET].
The “hour” digits light up, and the “minute” digits start fl ashing.
^{*1} If the clock uses the 12 hours AM/PM setting, the hour is displayed in the range of AM 1 to 12 / PM 1 to 12.
- ④ Press [▼/▲] to change the present “minute” in the range of 0 to 59.
Set the present minute and press [SET]. The day and time are set and the unit finishes the setting mode.

Note





- If the present time is invalid, “-- : --” is displayed. If the power failure occurs, check if the set data of day and time are valid.

How to Operate

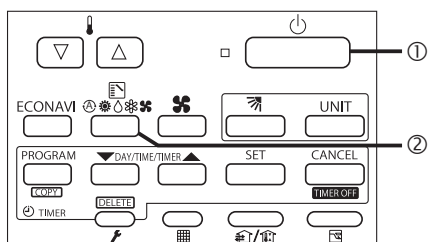
Turn on the indoor unit before operation. See operating instructions of the indoor unit.



Start/Stop operation / Operation mode

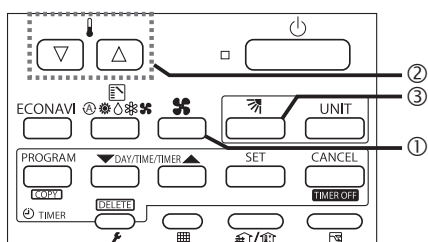

- ① Press [Start/Stop] to start operation.
 - ② Press the mode select button to select the mode among AUTO , HEAT , DRY , COOL  and FAN .
- * Auto: The mode is automatically switched to Cool or Heat to achieve the set temperature.

Fan speed / Set temperature / Flap



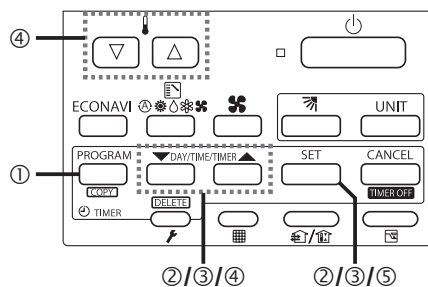

- ① Press the fan speed button to set the fan speed.
 : Automatically switches the fan speed.
- ② Press [∇/Δ] to set the desired temperature.
Cannot be set in Fan mode.
- ③ Press the flap button to adjust the flap position.

Weekly Program



- ① Press [PROGRAM] to enter the program confirmation mode.
- ② Select the day with [∇/Δ], and press [SET].
- ③ Select a Timer number with [∇/Δ], and press [SET].
- ④ Select the hour / minute / program pattern with [∇/Δ].
You can also set the temperature with [∇/Δ].
- ⑤ Press [SET] to store the timer programme.

Note

- If the heating performance is insufficient in Low  fan speed, change the fan speed to Medium  or High .
- The temperature range that can be set varies depending on the model.
- Temp sensor detects temperature in the vicinity of the air inlet of the indoor unit.
The detected temperature slightly differs from the room temperature depending on the installation condition.
The set temperature is a guideline of room temperature.

■ CZ-RTC5A

Part Names Control panel

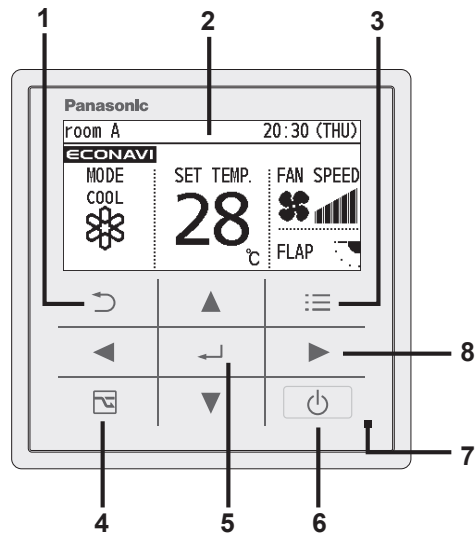

1 Return button

Returns to the previous screen.

2 LCD screen

3 Menu button

Displays the menu screen.

4 Energy saving button

Switches Energy saving/Normal operation.

5 Enter button

Fixes the selected content.

6 Start/Stop button

Starts/Stops operation.

7 Operation indicator

Illuminates during operation. Blinks during alarm.

8 Cross key buttons

Selects an item.

(◀ Left / ▼ Down / ▶ Right / ▲ Up)

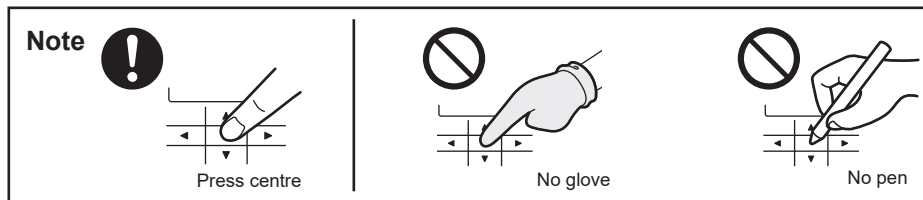

Screen display (Top screen)

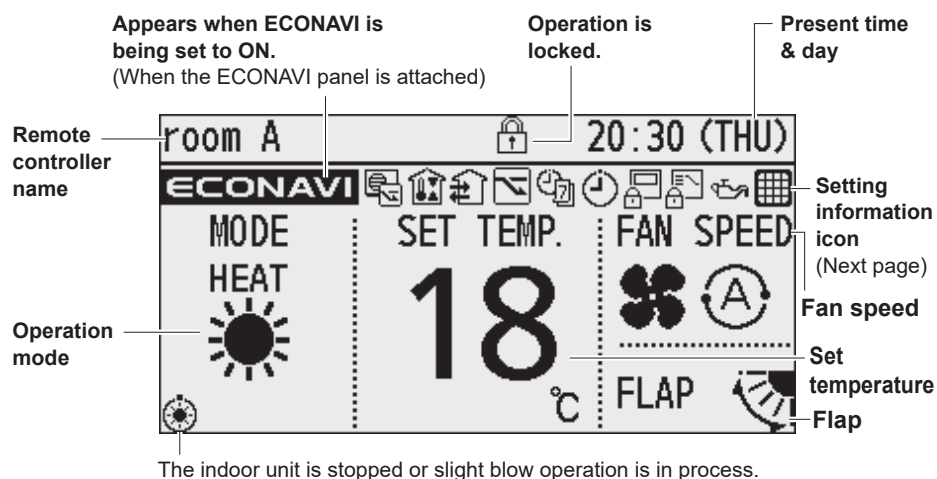

■ Setting information icons displayed on the top screen

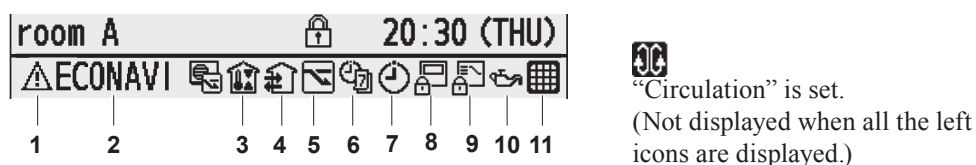

1 When inspection is required

2 Appears if there is a problem on ECONAVI.

3 Prevents the room temperature from increasing too much (or decreasing too much) when no one is in the room.

4 Fresh air is used for ventilation.

(Only when connecting a heat exchange ventilation unit or connecting a commercially sold fan.)

5 Energy saving operation is in process.

6 [Weekly timer] is set.

7 [ON/OFF timer] is set.

8 Remote control operation is restricted by a central control device.

9 Switching operation modes is prohibited.

(Switching to Auto mode is also prohibited.)

10 The engine oil needs to be replaced.

(Only when using a gas heat pump air conditioner.)

11 The indoor unit filter needs to be cleaned.

■ Item selection screen

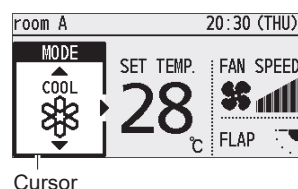

Cursor

■ Operation stop screen

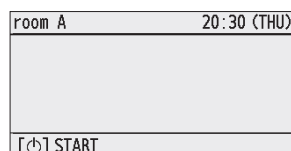

Operation guide

■ Lock screen display

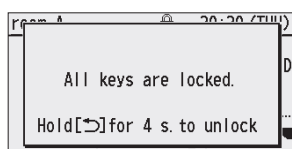

[Operation lock] is functioning.

- **To cancel lock**
Press [START] button for 4 seconds.

Screen display (Menu screen)

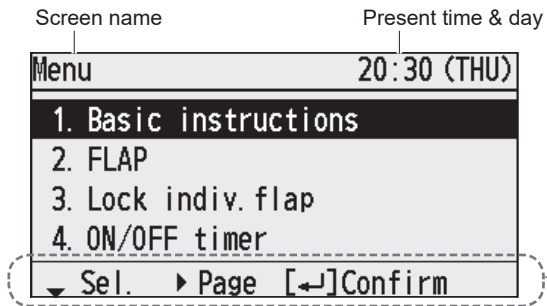

Operation guide

The currently operable content is simply displayed.

- ▲▼◀▶: Cross key buttons
- [↵]: Enter button

Basic Operations

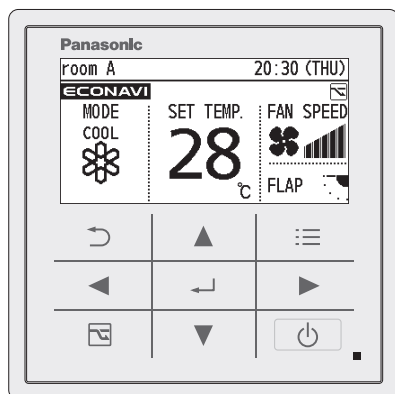

- ① Start operation.
Press .
(The operation indicator illuminates.)
 - ② Select the item to set.
Press .
 - ③ Change the setting.
Press → .
- (The cursor disappears.)

Note

- Operation modes that cannot be set are not displayed.
- The swing and airflow direction on the remote control is not synchronised with the flap movement.
- The flap display differs from the actual flap angle.
- Pressing after recovery from mains power failure will resume operation with the contents before mains power failure has occurred.
- If no operation is performed for a certain period of time, the backlight turns off to save electricity. (Press any button for illumination.)
- The energy saving operation restricts the maximum current value, resulting in decreased cooling/heating performance.
(If the current of outdoor units does not reach the peak due to low load operation, the current value is not restricted.)
- For models that cannot change the airflow direction, the airflow direction is not displayed.
- The fan speed and airflow direction in cooling/drying operation can be adjusted with 3 levels if controlling using one remote controller while assigning a indoor unit (e.g. ceilinghung type) which has a 3-level adjustment of fan speed and airflow direction in cooling / drying operation as main unit, and assigning a 4-way ceiling cassette type as sub unit.

■ Operation mode (e.g. Cool, Heat, etc.)

Press .

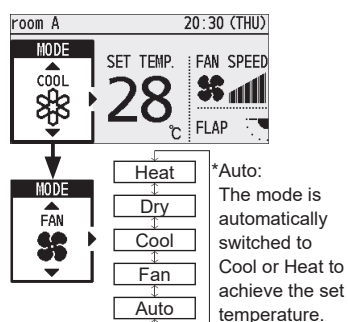

■ Set temperature

Press (When the cursor is not visible)

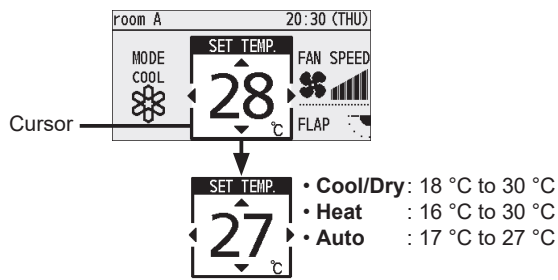

■ Fan speed

Press .

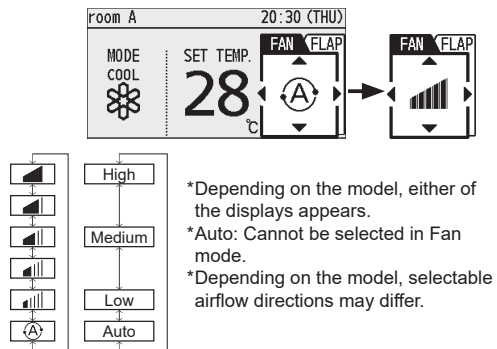

■ Flap

Press 2 times.

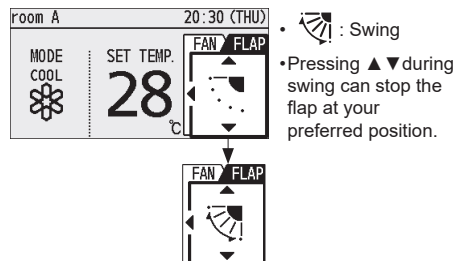

Outdoor unit	↑ DOWN UP ↓	P	Oil error time	Hr	P 0 0 0 0 0			
		10	Set engine rpm	min ⁻¹	1 0 2 2 0 0	600 to 2200		
		11	Engine rpm	min ⁻¹	1 1 2 2 0 0	600 to 2200		
		12	Compressor inlet pressure	MPa	1 2 0 1 0	0.60 to 0.90	0.30 to 1.10	
		13	Compressor outlet pressure	MPa	1 3 1 0 0	2.30 to 3.20	2.40 to 3.30	
		14	Compressor inlet temperature	°C	1 4 3 5 0	5 to 30	0 to 30	
		15	Compressor outlet temperature	°C	1 5 1 1 0 0	70 to 110	80 to 110	
		16	Outdoor heat exchanger 1 inlet temperature	°C	1 6 4 5 0	30 to 50	-5 to 10	
		20	Coolant temperature	°C	2 0 6 5 0	60 to 83	55 to 83	
		21	Outside air temperature	°C	2 1 2 8 0			
		22	Clutch 1 coil temperature	°C	2 2 5 0 0			
		24	Hot water outlet temperature	°C	2 4 - 3 5 0			
		26	Oil level measurement temperature	°C	2 6 - 3 2 0			
		31	Clutch 2 coil temperature	°C	3 1 5 0 0	30 to 90	30 to 90	
		34	Exhaust gas temperature	°C	3 4 6 5 0	45 to 90	40 to 80	
		38	Outdoor fan 1	%	3 8 1 0 0 0	0 to 108	0 to 90	
		39	Outdoor fan 2	%	3 9 1 0 0 0	0 to 108	0 to 90	
		41	Outdoor fan 1 revolutions	min ⁻¹	4 1 6 5 0	0 to 700	0 to 580	
		42	Outdoor fan 2 revolutions	min ⁻¹	4 2 6 5 0	0 to 700	0 to 580	
		44	Set coolant pump	min ⁻¹	4 4 3 0 0 0	3700	3700	
45	Coolant pump revolutions	min ⁻¹	4 5 3 0 0 0	3700	3700			
46	Throttle	Step	4 6 3 3 0					
47	Fuel gas adjustment valve	Step	4 7 3 3 0					
48	Liquid valve	Step	4 8 2 2 0	0 to 100	0 to 480			
49	Bypass valve	Step	4 9 1 0 0	20	20			
50	Outdoor electric valve 1	Step	5 0 4 8 0	480	0 to 480			
51	Outdoor electric valve 2	Step	5 1 4 8 0	480	0 to 480			
52	Coolant 3-way valve	Step	5 2 1 0 0	50	50 to 1950			
53	Electric cooler valve	Step	5 3 1 0 0	50 to 1950	50 to 1950			
54	Hot water discharge 3-way valve	Step	5 4 1 0 0	50 to 1950	50 to 1950			
55	Rotation speed variation value (F rpm)		5 5 0 0 0 0					
59	Engine load ratio		5 9 3 0	0 to 6	0 to 6			
60	Engine ignition timing	Degrees	6 0 1 0	8 to 40	8 to 40			
61	Cylinder number when flameout		6 1 1					

Outdoor unit	DOWN UP	65	Gas demand regulation value	%	65.000		
		66	Gas demand input value	%	66.000		
		70	Number of units with thermostat on	Units	70.20		
		71	Thermostat-on average intake temperature	°C	71.194		
		72	Thermostat-on average blow out temperature	°C	72.150		
		73	Thermostat-on average E1 temperature	°C	73.50		
		74	Thermostat-on average E2 temperature	°C	74.60	.	.
		75	Thermostat-on average E3 temperature	°C	75.70	.	.
Indoor unit	DOWN UP	01	Indoor No. 1 unit electric valve opening	Step	011180	64 to 350	300 to 480
		02	Indoor No. 1 unit intake temperature	°C	012.290		
		03	Indoor No. 1 unit blow out temperature	°C	013.150		
		04	Indoor No. 1 unit E1 temperature	°C	014.100		
		05	Indoor No. 1 unit E2 temperature	°C	015.100		
		06	Indoor No. 1 unit E3 temperature	°C	016.100		
		01	Indoor No. 2 unit electric valve opening	Step	02.1180		
		:	*1				
06	Indoor No. 48 unit E3 temperature	°C	48.6100				

***1: The indoor unit data display shows the data for the number of connected indoor units (maximum of up to 64 units) in the same order.**

③ Checking mode changes

For these checks select a mode that is different from the mode in which the performance checks were carried out.

❶ Press the HOME (SW004) key to display the menu item number. “ ㄱ ㄴ ㄷ ㄹ ” (Figure 8)

❷ Next, press the UP (SW005) or DOWN (SW006) key to select menu item number “ ㄱ ㄴ ㄷ ㅅ ” (Figure 9)

❸ After “ ㄱ ㄴ ㄷ ㅅ ” has been displayed, display the test run/forced setting display “ ㄷ ㅅ ㄹ ㅅ ”. While in test run/forced setting display press the SET (SW007) key. (Figure 10)

❹ When the SET (SW007) key is pressed in the test run/forced setting, the display changes. Use the UP (SW005) or DOWN (SW006) key to select the forced cooling test run mode “ ㄷ ㅅ ㄹ ㅅ ” or forced heating test run mode “ ㅅ ㅅ ㄹ ㅅ ”. (Figure 11)

- When in heating mode change to cooling mode
- When in cooling mode change to heating mode

❺ When in the forced test run setting mode, press the SET (SW007) key for longer than 1 second and the mode changes to cooling (heating) test run. At this stage check the following.

- The thick tubes are hot when heating mode is selected (do not touch the tubes with your bare hand)
- The thick tubes are cold when cooling mode is selected.

④ Stopping the test run

❶ Press the HOME (SW004) key to display the menu item number. “ ㄱ ㄴ ㄷ ㄹ ” (Figure 8)

❷ Next, press the UP (SW005) or DOWN (SW006) key to select menu item number “ ㄱ ㄴ ㄷ ㅅ ” (Figure 9)

❸ After “ ㄱ ㄴ ㄷ ㅅ ” has been displayed, display test run/forced setting “ ㄷ ㅅ ㄹ ㅅ ”. In test run/forced setting display press the SET (SW007) key. (Figure 10)

❹ When the SET (SW007) key is pressed when the status is test run/forced setting display, the display changes. Use the UP (SW005) or DOWN (SW006) key to select the forced cooling test run mode “ ㄷ ㅅ ㄹ ㅅ ”, or the forced heating test run mode “ ㅅ ㅅ ㄹ ㅅ ”. Then press the SET (SW007) key for longer than 1 second. The TEST/WARNING indicator (red LED (LED052)) goes off, and the state returns to forced setting selection. (Figure 11)

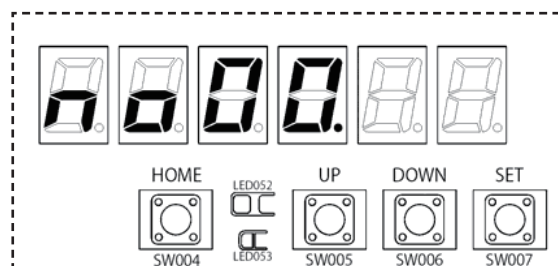

Figure 8

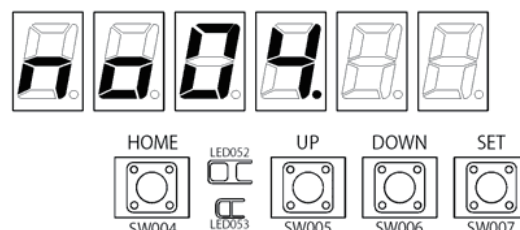

Figure 9

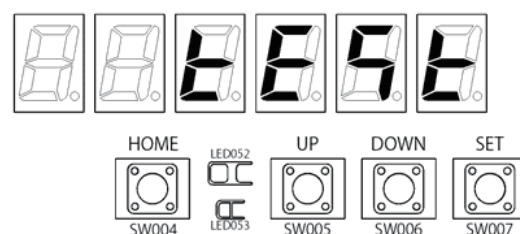

Figure 10

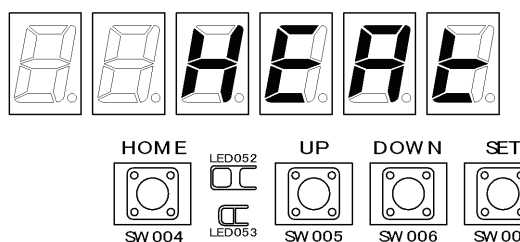
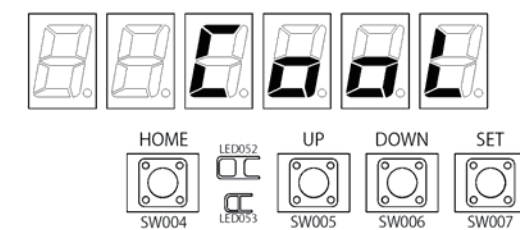

Figure 11

❻ If as a result of the above a fault has been detected, carry out an investigation, correction or improvement in accordance with the separate “Service and Technical Reference Manual Type M1 Series, Troubleshooting.”

(2) Completion of operations

Check again that there are no omissions in the test run check list record, or that there are no malfunctioning items.

IV. Board Switch and LED arrangement diagram

1. U-20GES3E5

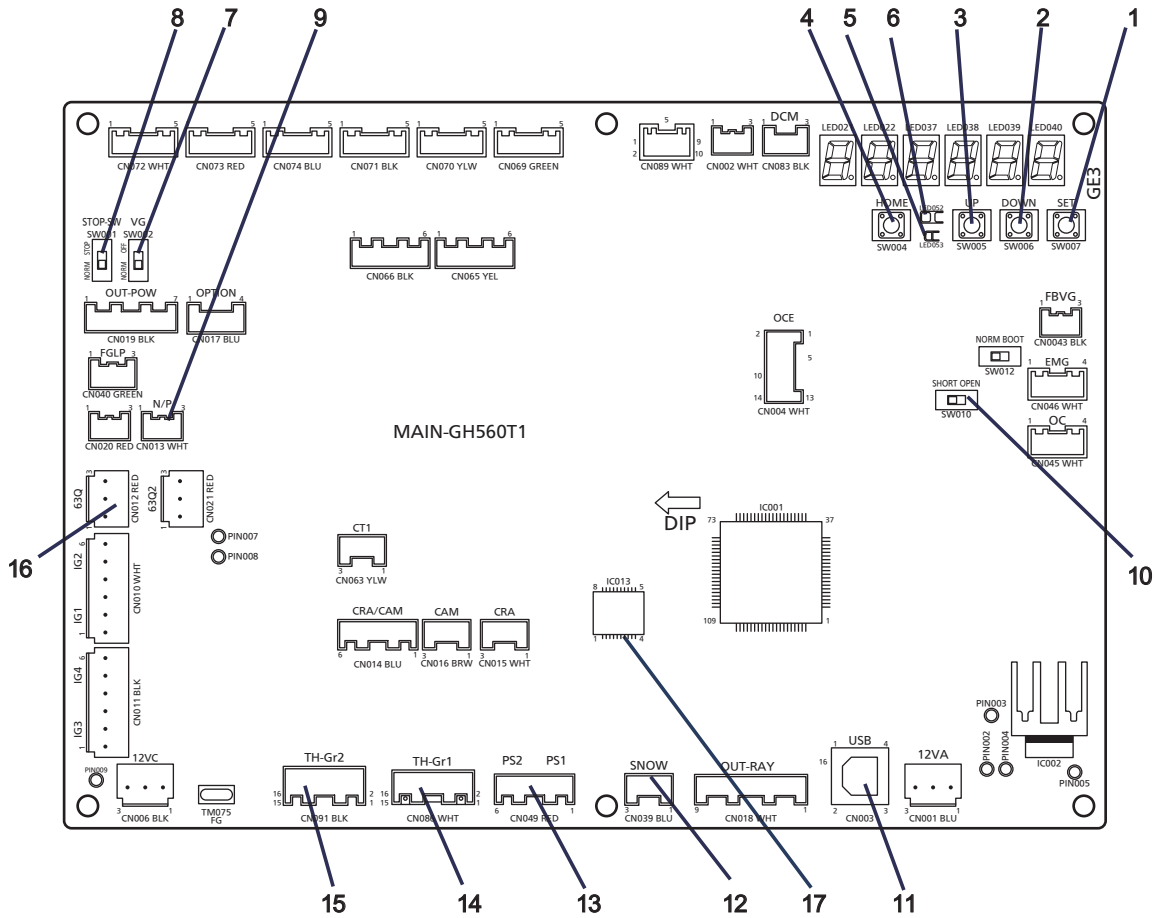

No.	Name	No.	Name
1	SET key (SW007)	14	CN086 (WHITE) TH1 to TH3, TH6 to TH8, TH9, TH14
2	DOWN key (SW006)	15	CN091 (BLACK) TH4 to TH5, TH10 to TH13, TH16 to TH17
3	UP key (SW005)	16	CN012 (RED) Oil Pressure SW Input
4	HOME key (SW004)	17	EEPROM
5	LEVEL LED (LED053)	TH1:	Compressor inlet temperature
6	TEST/WARNING LED (LED052)	TH2:	Compressor outlet temperature
7	Fuel gas solenoid valve forced closing switch (SW002)	TH3:	Heat exchanger inlet temperature
8	STOP SW (SW001)	TH4:	Sub-evaporator outlet temperature
9	CN013 (WHITE) N/P (gas type changeover port)	TH5:	Heat exchanger inlet temperature
10	Terminal resistor ON/OFF switch (SW010)	TH6:	Coolant temperature
11	USB port	TH7:	Outdoor air temperature
12	CN039 (BLUE) snowfall sensor	TH8:	Clutch 1 coil temperature
13	CN049 (RED) Compressor outlet/inlet pressure sensors PS1: Inlet, PS2: outlet	TH9:	Catalyst temperature
		TH10:	Hot water outlet/sub-evaporator
		TH11:	Oil level measurement temperature
		TH14:	Clutch 2 coil temperature
		TH16:	Overcooling outlet temperature
		TH17:	Cooling water outlet temperature

2. U-10MES2E8

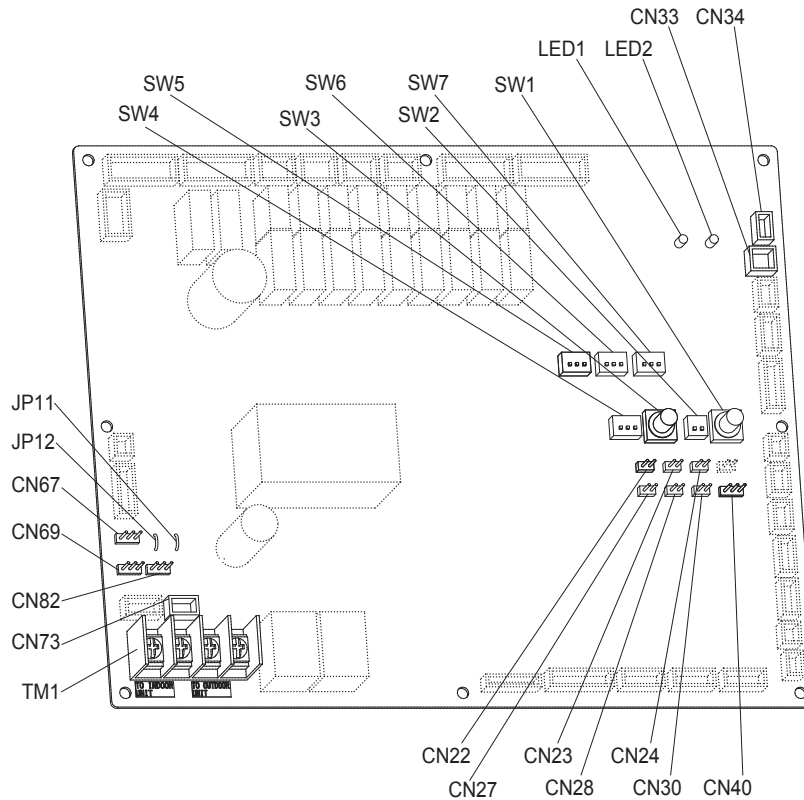

● Name And Function Of Each Switch On Outdoor Unit Control P.C.Board

Function Switch	Remarks
MODE pin (3P, BLK) (CN40)	Changes to cooling/heating mode. (Outdoor main unit is only usable.) When in normal operation: When short circuited the COOL side, indoor unit operation in the same refrigerant system changes to all cooling mode. When short circuited the HEAT side, indoor unit operation in the same refrigerant system changes to all heating mode. When in auto address setting: Changes to heating mode with open-circuit.
A.ADD pin (2P, WHT) (CN30)	Short circuited for over 1 second long → Auto address setting starts with open-circuit. If short circuit lasts for over 1 second long during auto address setting, the setting is interrupted.
CHK pin (2P, WHT) (CN23)	When short circuited, test run begins. (If the remote controller is connected in test run mode, it is automatically cancelled after 1 hour.) Also, if short-circuit is cancelled, test run mode is cancelled.
RC plug (3P, BLU) (CN73)	Connects to outdoor unit maintenance remote controller and content of alarm message will be checked.
RUN pin (2P, WHT) (CN27)	When short circuited and pulse signal is given, all indoor units operate in the same refrigerant system.
STOP pin (2P, WHT) (CN28)	When short circuited and pulse signal is given, all indoor units stop in the same refrigerant system. (When short circuited, operation cannot be performed by the indoor unit's remote controller.)
AP pin (2P, WHT) (CN24)	Can be used when vacuuming the outdoor unit.
SNOW plug (3P, RED) (CN34)	Can be used when installing a snowfall sensor device.
SILENT plug (2P, WHT) (CN33)	Can be used when setting the outdoor unit fan in sound absorbing mode.
OC EMG terminal (3P, BLK) (CN69)	If "TO INDOOR UNIT" accidentally connected to high voltage, use the terminal base TM1. Method: 1. Replace the pins 1 and 2 of CN69 with the pins 2 and 3. 2. Disconnect JP1
RC1 EMG terminal (3P, BLK) (CN82)	If "TO OUTDOOR UNIT" accidentally connected to high voltage, use the terminal base TM1. Method: 1. Replace the pins 1 and 2 of CN82 with the pins 2 and 3. 2. Disconnect JP1

GHP Test Run Checklist

Model Name: U-

Manufacturing No.:

Indoor	1)S-	11)S-	21)S-	31)S-	41)S-
	2)S-	12)S-	22)S-	32)S-	42)S-
	3)S-	13)S-	23)S-	33)S-	43)S-
	4)S-	14)S-	24)S-	34)S-	44)S-
	5)S-	15)S-	25)S-	35)S-	45)S-
	6)S-	16)S-	26)S-	36)S-	46)S-
	7)S-	17)S-	27)S-	37)S-	47)S-
	8)S-	18)S-	28)S-	38)S-	48)S-
	9)S-	19)S-	29)S-	39)S-	
	10)S-	20)S-	30)S-	40)S-	

- 1. Installation check**
- Equipment external visual, damage, missing parts check (outdoor unit)
 - Equipment external visual, damage, missing parts check (indoor unit)
 - Indoor unit/outdoor unit installation condition check
 - Outdoor unit anti-vibration mat, cradle condition
 - Drain tubing condition (outdoor unit)
 - Drain tubing condition (indoor unit)
 - Refrigerant tubing connections leak check (air-tightness test)
 - Electrical power wire, signal wire connection condition check
 - Removal of the indoor unit fixing pad
 - Earth installation check
 - Leakage current breaker installation check
 - Amount of additionally charged refrigerant check (kg)
 - Refrigerant tubing length (m)

- 3. Function check**
- Remote controller
 - Operation check
 - Check of changing air velocity and auto-flap operation
 - Temperature setting check
 - Central control function
 - ()
 - Operation check
- 4. Engine system check**
- Engine starting condition (starting performance)
 - Error vibration and sound check
 - Check for external leak of oil and coolant
 - Harness installation state
- 5. Operation data collection**
- Data collection
 - [Operating mode: · After operation min.]
 - (Operate all indoor units, and take measurements)

	Max.	Min.
Main tubing length		-
Branch tubing length		
High/low difference		

Outdoor unit operation data		Outdoor unit 1	Outdoor unit 2	Outdoor unit 3
Measurement item (sensor name)	Unit	Measurement value	Measurement value	Measurement value
Number of engine revolutions	min ⁻¹			
Compressor inlet pressure	MPa			
Compressor outlet pressure	MPa			
Compressor inlet temperature	°C			
Compressor outlet temperature	°C			
Outdoor heat exchanger inlet temperature	°C			
Outdoor heat exchanger outlet temperature	°C			
Outdoor air temperature	°C			
Coolant temperature	°C			
Outdoor fan temperature	%			
Degree of opening of outdoor unit solenoid valve	step			
Degree of opening of outdoor unit liquid valve	step			
Degree of opening of outdoor unit bypass valve	step			
Degree of superheat of compressor intake	°C			

(Units: Degree of opening: Step; Temperature °C)

- Insulation resistance check (Power Equipment)
 - Power side MΩ
 - Equipment side MΩ
 - Fuel tubing connectors leakage check
- 2. Checks and preparations before operation**
- Crankcase heater energized for 5 hours
 - Opening of closing valve (liquid side, gas side)
 - Check power phase
 - Fuel gas type check and setting
 - Coolant level check
 - Stop switch setting
 - Gas solenoid valve switch setting check
 - Number of indoor units connected setting
 - Outdoor unit address and terminal resistance setting
 - Check of date and time, and adjustment
 - ROM version number check
 - Ver _____

OK: ○, NG: ×, Satisfactory after maintenance: ●, Work complete: ⌘, Not applicable: -, Adjusted: A, Tightened: T, Cleaned: C, Filled: L, Changed: E

GHP Test Run Checklist

Function Name: U-

Manufacturing No.:

Indoor	1)S-	11)S-	21)S-	31)S-	41)S-
	2)S-	12)S-	22)S-	32)S-	42)S-
	3)S-	13)S-	23)S-	33)S-	43)S-
	4)S-	14)S-	24)S-	34)S-	44)S-
	5)S-	15)S-	25)S-	35)S-	45)S-
	6)S-	16)S-	26)S-	36)S-	46)S-
	7)S-	17)S-	27)S-	37)S-	47)S-
	8)S-	18)S-	28)S-	38)S-	48)S-
	9)S-	19)S-	29)S-	39)S-	
	10)S-	20)S-	30)S-	40)S-	

Indoor unit operation data

6. Special instructions

Unit No.	Degree of opening electric valve	Intake temperature	Discharge temperature	Coil inlet temperature	Coil outlet temperature
1					
2					
3					
4					
5					
6					
7					
8					
9					
10					
11					
12					
13					
14					
15					
16					
17					
18					
19					
20					
21					
22					
23					
24					
25					
26					
27					
28					
29					
30					
31					
32					
33					
34					
35					
36					
37					
38					
39					
40					
41					
42					
43					
44					
45					
46					
47					
48					

(Units: Degree of opening: Step; Temperature °C)

OK: ○, NG: ×, Satisfactory after maintenance: ●, Work complete: ⚡, Not applicable: -, Adjusted: A, Tightened: T, Cleaned: C, Filled: L, Changed: E

Panasonic[®]